

SPEKTRUMTM

DX6

**6-Channel, 10-Model Memory
DSM Parkflyer and
Micro Helicopter System**



Welcome to the World of Spektrum Technology

No longer will you have to wait for an open frequency or struggle with interference caused by noisy motors, speed controllers or metal-to-metal noise. Gone are concerns of being shot down by someone inadvertently turning on on your frequency. With Spektrum™—when you're ready, just turn on and fly!

Your DX6 transmits on the 2.4GHz band and utilizes DSM™ Digital Spread Spectrum Modulation, making it impervious to interference. The system features patented DualLink™ (pat pend) technology that actually transmits and receives on two frequencies simultaneously, offering multi-path security.

Parkflyers Only

The DX6 system is designed for parkflyer type aircraft only. This includes all forms of compact electric and non-powered airplanes as well as micro electric helicopters. While the system has more than adequate range for these types of aircraft, it is imperative that the system not be used in larger aircraft that could exceed the range.

How DSM Works

Transmitter

When the transmitter is turned on, the system scans the 2.4GHz band, finds an open channel and locks on that channel. Next the transmitter scans for a second open channel and, when found, transmits on that second open channel. The system is now transmitting simultaneously on two 2.4GHz channels, giving two paths of security.

Receiver

Each AR6000 receiver features patented DualLink (pat pend) technology and is actually two receivers in one, hence the dual antennas. When turned on, the first receiver scans the 2.4GHz band until it finds the specific transmitter's code (called GUID) that it has been programmed to recognize (see binding page 24) and locks on that signal. Then the second receiver scans the 2.4GHz band, finds the second transmitted code that it's been programmed to recognize and locks on that signal. This whole process takes less than 5 seconds. The receiver is then locked to that transmitter via two independent channels, and is virtually immune to model generated or outside interference.

Thanks for joining the Spektrum family and have fun flying!

Spektrum Development Team

Alternate Languages

ITALIAN: Per la versione italiana di questo manuale vi preghiamo di visitare il sito
www.spektrumrc.com

FRENCH: Pour consulter ce manuel en français, visiter le site www.spektrumrc.com

GERMAN: Zur Ansicht der Bedienungsanleitung in den Deutsch besuchen Sie bitte
www.spektrumrc.com

SPANISH: Para ver este manual en Español entra en www.spektrumrc.com

Table of Contents

Welcome to the World of Spektrum™ Technology	2
Parkflyers Only	2
How DSM™ Works	2
Transmitter	2
Receiver	2
Alternate Languages	3
Aircraft Quick Start: 4-Channel Airplane w/Single Rates	6
Binding	6
Model Type Selection	6
Digital Trim Settings	7
Servo Reversing	7
Travel Adjustment	8
Helicopter Quick Start: 5-Channel Mechanical Mix Helicopters	9
Binding	9
Model Type Selection	9
Digital Trim Settings	10
Servo Reversing	10
Travel Adjustment	11
Pitch Curve	12
Throttle Curve	13
Important Gyro Information	14
User Guide	14
System Features	14
Airplane Specific Features	14
Helicopter Specific Features	15
AR6000 Receiver	15
Receiver Specifications	15
Servo Specifications	16
Charging the Transmitter	17
Transmitter	17
Important	17
Trainer System	18
Operating the Trainer System	18
Control Identification and Location - Airplane	19

Aircraft Programming Guide

CHAPTER 1: TRANSMITTER CONTROLS	21
Digital Trim Levers.....	21
Receiver Channel Assignment	21
Transmitter Throttle Alt	21
Lithium Battery	22
Control Stick Length Adjustment	22
Neck Strap Attachment.....	22
Receiver Antenna Mounting.....	22
Range Testing	23
Binding.....	24
Smart Fail-Safe.....	24
CHAPTER 2: CONNECTIONS.....	25
Connections	25
CHAPTER 3: KEY INPUT AND DISPLAY	26
Key Input and Display.....	26
CHAPTER 4: BATTERY ALARM AND DISPLAY	26
Throttle Cut.....	26
CHAPTER 5: INPUT MODE AND FUNCTION	27
Normal Display.....	27
Direct Trim Access Display	27
System Mode.....	28
Function Mode	29
CHAPTER 6: FUNCTIONS (SYSTEM MODE)	30
Model Type Selection	30
Data Reset.....	31
Dual Rate Switch Selection	32
Wing Type Selection	33
Flaperon Setup	33
V-Tail	34
Delta-Wing Mixing	35
Model Selection.....	36
Model Name Entry	37
CHAPTER 7: FUNCTIONS (FUNCTION MODE)	38
Servo Reversing	38
Dual Rate	39
Exponential.....	40
Sub-Trim	41
Travel Adjustment.....	42
Aileron-to-Rudder Mixing.....	43
Aileron-to-Rudder Mixing Switch Selection.....	44
Elevator-to-Flap Mixing	45
Elevator-to-Flap Mixing Switch Selection	46
Differential	47
Flap-to-Elevator Offset Trim	48
Programmable Mixing (A, B, C).....	49
Offset	52
Programming a Rudder Dual Rate.....	53
CHAPTER 8: DATA SHEET	55

Helicopter Programming Guide

CHAPTER 1: TRANSMITTER CONTROLS	57
Digital Trim Levers.....	57
Receiver Channel Assignment	57
Transmitter Throttle Alt	57
Lithium Battery	58
Control Stick Length Adjustment	58
Neck Strap Attachment.....	58
Receiver Antenna Mounting.....	58
Range Testing	59
Binding.....	60
Smart Fail-Safe.....	60
CHAPTER 2: CONNECTIONS.....	61
Connections	61
CHAPTER 3: KEY INPUT AND DISPLAY	62
Key Input and Display.....	62
CHAPTER 4: BATTERY ALARM AND DISPLAY	62
Throttle Cut.....	62
CHAPTER 5: INPUT MODE AND FUNCTION	63
Normal Display.....	63
Direct Trim Access Display	63
System Mode.....	64
Function Mode	65
CHAPTER 6: FUNCTIONS (SYSTEM MODE)	66
Model Type Selection	66
Data Reset.....	67
Dual Rate Switch Selection	68
Gear/Gyro Switch Selection	69
Important Gyro Information.....	69
Model Selection.....	70
Model Name Entry	71
CHAPTER 7: FUNCTIONS (FUNCTION MODE)	72
Servo Reversing	72
Dual Rate	73
Exponential.....	74
Sub-Trim	75
Travel Adjustment	76
Throttle Hold.....	77
Pitch Curve.....	78
Throttle Curve.....	80
Revolution Mixing	82
Programmable Mixing (A)	83
Offset	86
Programming a Rudder Dual Rate.....	87
CCPM Swashplate Mixing.....	88
CCPM Servo Locations	90
CCPM Servo Connections.....	91
Important Gyro Information.....	91
CHAPTER 8: DATA SHEET	92

Warranty

One Year Warranty	93
FCC Information	94
Notes	95

Aircraft Quick Start: 4-Channel Airplane w/Single Rates

Binding

Binding is the process of programming the receiver to recognize the code of a single specific transmitter. In order for the receiver to operate it must be bound to the transmitter.

Note: Your receiver was bound to the transmitter during manufacturing and is ready to install with the fail-safe positions set to low throttle during the binding process. If you wish to change these fail-safe positions after the Quick Start Setup see page 24 for binding details.

Important: Remove the bind plug after binding.

Model Type Selection

Selecting the Airplane Mode

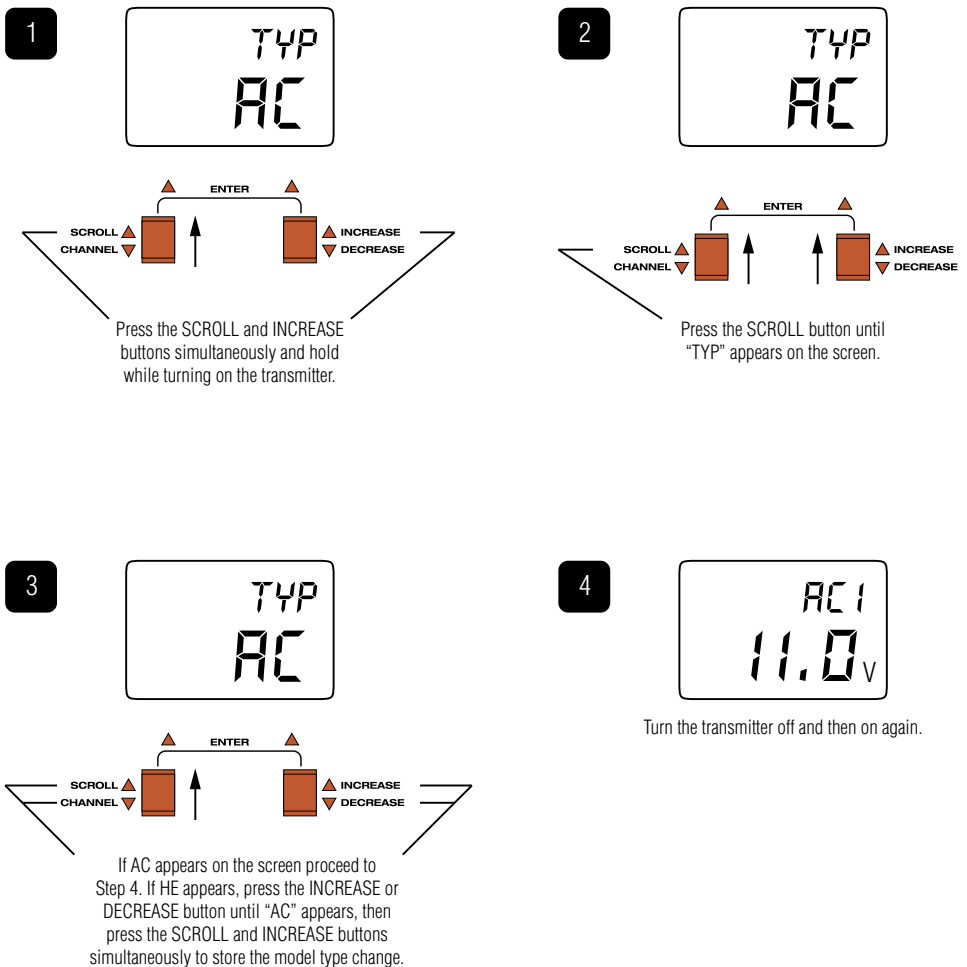

Digital Trim Settings

Centering the Digital Trims

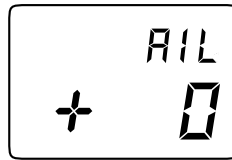

If necessary move the throttle, aileron, elevator, and rudder trims to neutral by moving each trim lever while noting the trim position on the screen. The throttle, aileron, elevator and rudder trims should all be set to 0.

Servo Reversing

Establishing Servo Direction

1

A digital display showing the word 'THR' in the top right and 'REV-NORM' in the bottom right.

Press the SCROLL and INCREASE buttons simultaneously and hold while turning on the transmitter.

A diagram of a transmitter with two buttons. The left button is labeled 'SCROLL CHANNEL' with up and down arrows. The right button is labeled 'INCREASE DECREASE' with up and down arrows. An 'ENTER' button is located between them. Arrows point from the SCROLL and INCREASE buttons towards the digital display above.

2

A digital display showing the word 'THR' in the top right and 'REV-NORM' in the bottom right.

With the transmitter on, press the SCROLL and INCREASE buttons upward simultaneously until a beep is heard.

A diagram of a transmitter with two buttons. The left button is labeled 'SCROLL CHANNEL' with up and down arrows. The right button is labeled 'INCREASE DECREASE' with up and down arrows. An 'ENTER' button is located between them. Arrows point from the SCROLL and INCREASE buttons towards the digital display above.

3

A digital display showing the word 'THR' in the top right and 'REV-NORM' in the bottom right.

Press the SCROLL button (if necessary) until "REV-NORM" appears on the screen.

A diagram of a transmitter with two buttons. The left button is labeled 'SCROLL CHANNEL' with up and down arrows. The right button is labeled 'INCREASE DECREASE' with up and down arrows. An 'ENTER' button is located between them. An arrow points from the SCROLL button towards the digital display above.

4

A digital display showing the word 'THR' in the top right and 'REV-NORM' in the bottom right.

Press the CHANNEL button to select the channel you want to reverse. Press the INCREASE or DECREASE button to reverse the direction of the channel you selected.

A diagram of a transmitter with two buttons. The left button is labeled 'SCROLL CHANNEL' with up and down arrows. The right button is labeled 'INCREASE DECREASE' with up and down arrows. An 'ENTER' button is located between them. Arrows point from both buttons towards the digital display above.

Travel Adjustment

Establishing Servo Travel

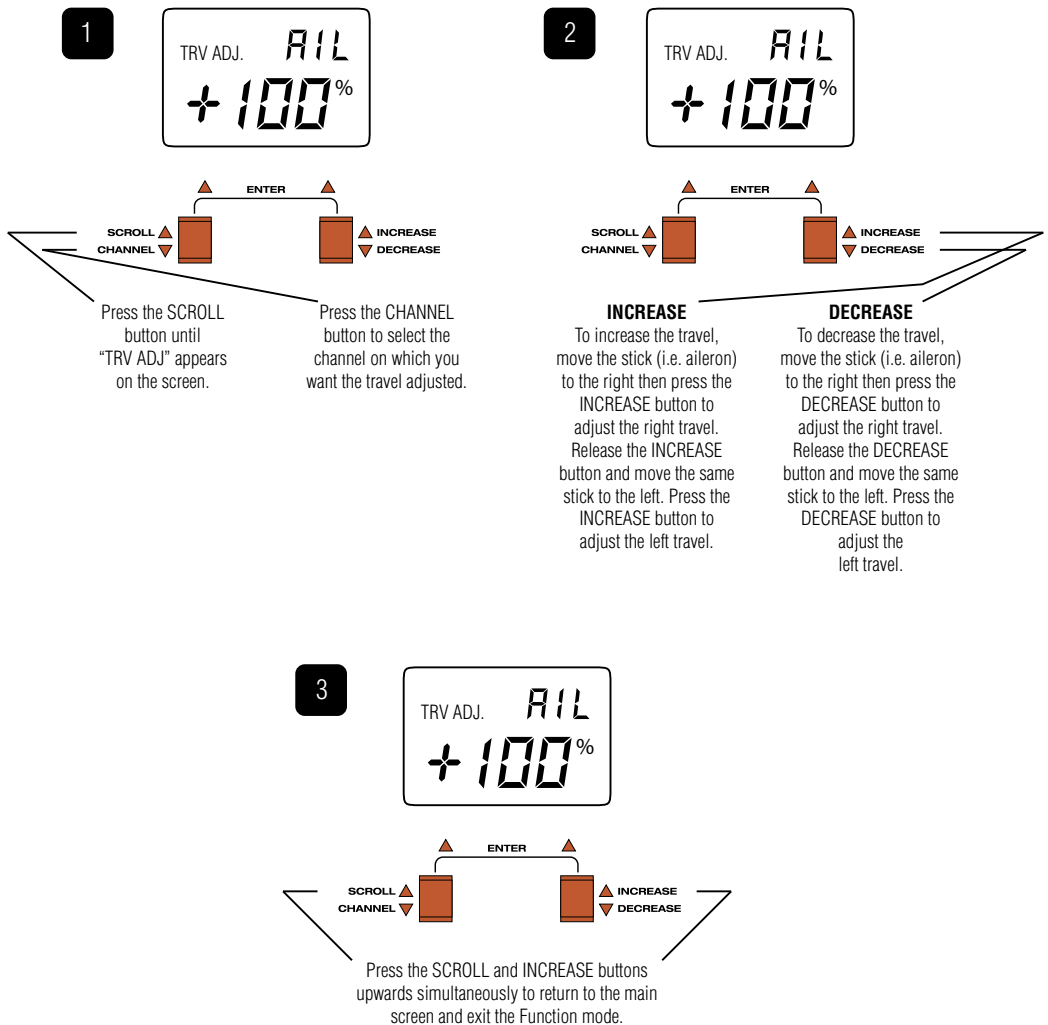

This completes the basic Quick Start setup for your airplane. For additional features like Dual Rate, Exponential, Mixing, etc., see the appropriate pages in the Table of Contents.

Note: If your airplane's ailerons are controlled independently by two servos see "Wing Type Selection" on page 33 for specifics on programming flaperons.

Helicopter Quick Start: 5-Channel Mechanical Mix Helicopters

Binding

Binding is the process of programming the receiver to recognize the code of a single specific transmitter. In order for the receiver to operate it must be bound to the transmitter.

Note: Your receiver was bound to the transmitter during manufacturing and is ready to install with the fail-safe positions set to low throttle during the binding process. If you wish to change these fail-safe positions after the Quick Start Setup, see page 60 for binding details.

Important: Remove the bind plug after binding.

Model Type Selection

Selecting the Helicopter Mode.

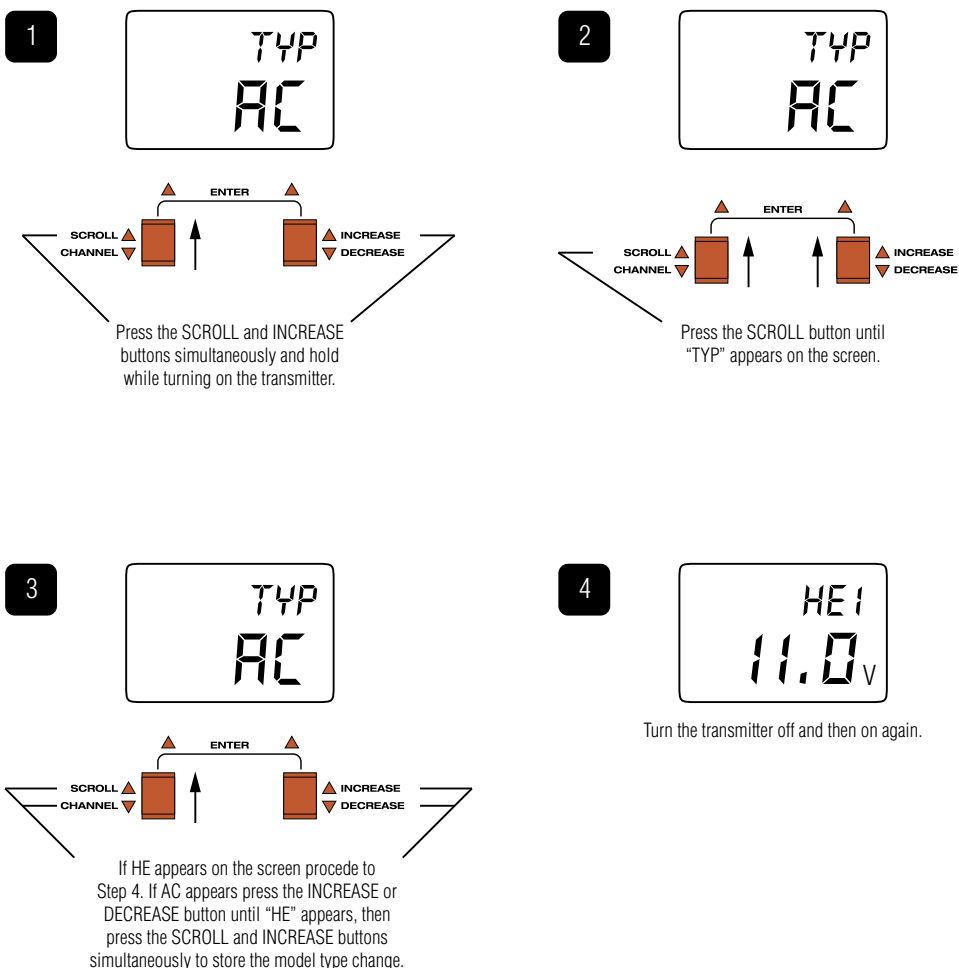

Digital Trim Settings

Centering the Digital Trims

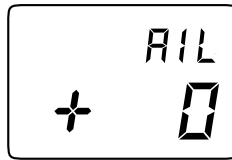

If necessary move the throttle, aileron, elevator, and rudder trims to neutral by moving each trim lever while noting the trim position on the screen. The throttle, aileron, elevator and rudder trims should all be set to 0.

Servo Reversing

Establishing Servo Direction

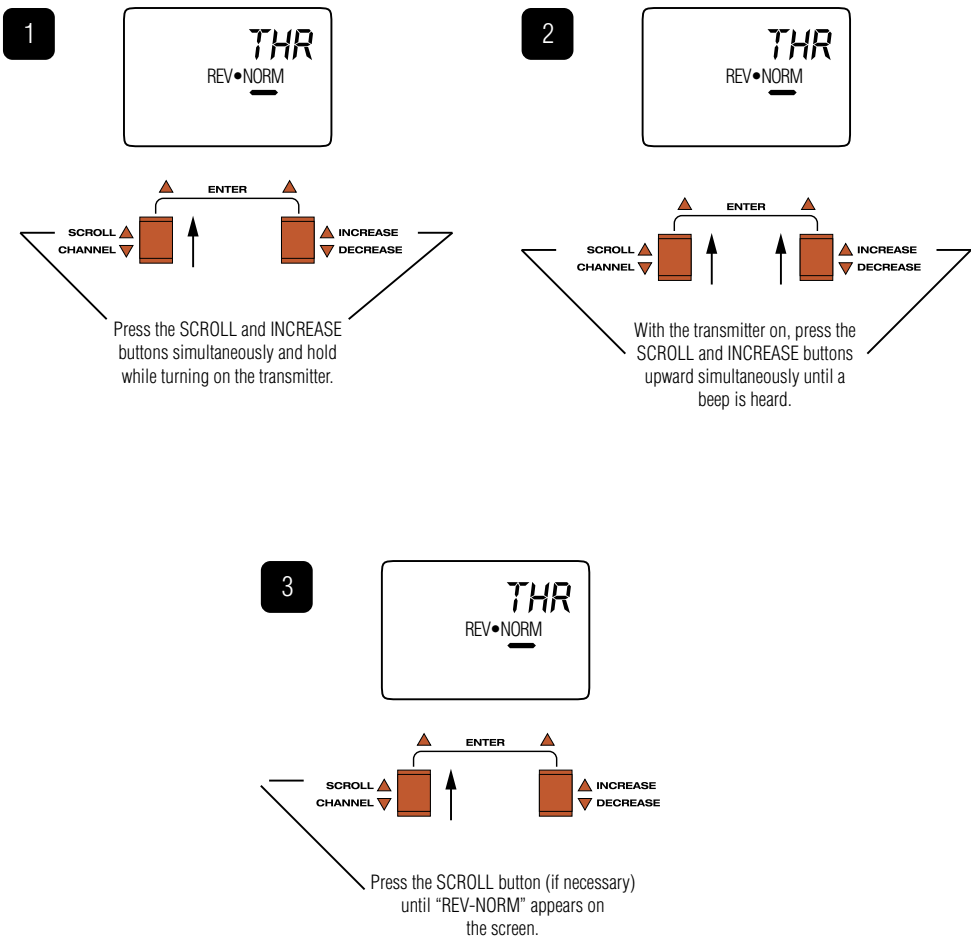

Travel Adjustment

Establishing Servo Travel

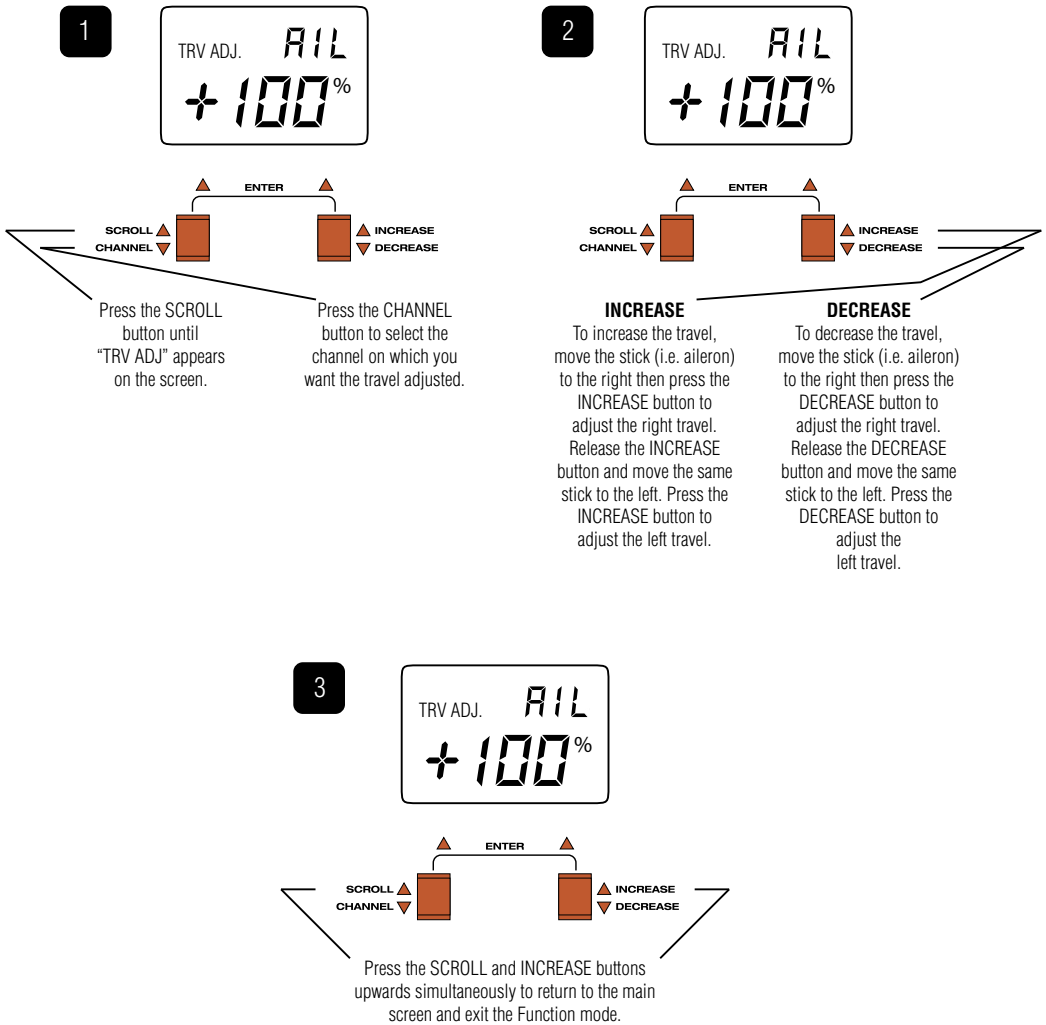

Pitch Curve

Adjusting the Normal Pitch Curves

The DX6 offers three independent pitch curves with three adjustable points per curve. This function allocates a separate pitch curve setting during Normal, Stunt, and Throttle Hold modes to maximize flight performance. Once the pitch curves are established, each can be activated in flight, using the two-position flight mode switch and the throttle hold switch. Each of the three points on the pitch curve are independently adjustable from 0–100%. These three points correspond to the low, middle, and high positions of the throttle stick (collective). The factory preset values for all three pitch curves are: Low 0%, Middle 50%, and High 100%. See page 78 for more information regarding the Pitch Curve function.

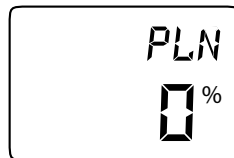
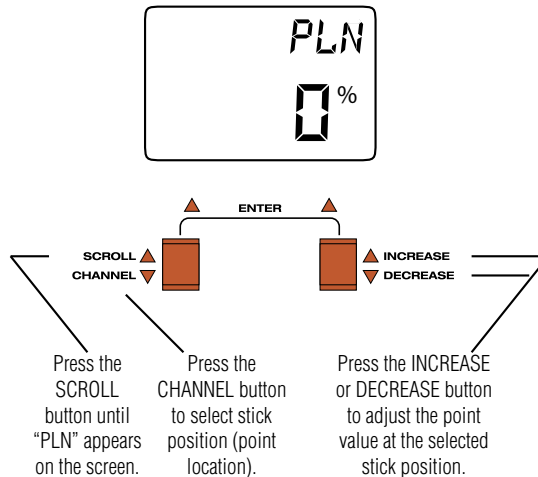

STICK POSITION (POINT LOCATION)

L = Low
2 = Center
H = High

PRESET VALUES

L = 0%
2 = 50%
H = 100%

RECOMMENDED INITIAL PITCH SETTINGS

(Please refer to your helicopter kit instructions for pitch settings if available)
L = 0° Pitch
2 = 5° Pitch
H = 9° Pitch

Throttle Curve

Adjusting the Normal Throttle Curve

Adjustment of the throttle curve is very similar to the pitch curve adjustment described in the preceding section. Two throttle curves are available—normal and stunt. The normal or hover throttle curve has three points (L, 2, H) and the stunt or flight throttle curve has two points (L and 2). The two throttle curves are activated by the flight mode switch located on the top left rear corner of the transmitter. The throttle curve is in the normal mode when the flight mode switch is in the back position. The throttle curve is in the stunt mode when the flight mode switch is in the forward position. See page 80 for more information regarding the Throttle Curve function.

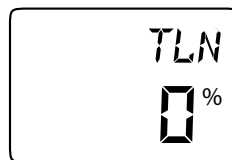
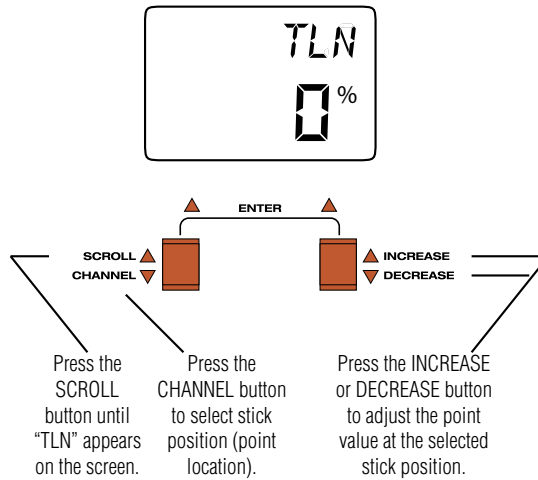

STICK POSITION
(POINT LOCATION)

L = Low
2 = Center
H = High

PRESET VALUES

L = 0%
2 = 50%
H = 100%

This completes the basic Quick Start setup for your helicopter. For additional features like additional pitch and throttle curves, throttle hold, remote gyro gain, etc., see the appropriate pages in the Table of Contents.

Note: For CCPM helicopter setup see page 88.

Important Gyro Information

Note: After flight trimming the helicopter, or anytime the rudder trim is changed, it is important to rebind the system (see Binding page 60) to set the fail-safe position to the rudder's true neutral. With many types of gyros, each time the radio is turned on the gyro senses the servo output position and establishes this as the center for that flight.

When the DX6 receiver is first turned on, the servos are driven to their fail-safe positions until the receiver connects to the DX6 transmitter. This can take several seconds. If the fail-safe position for rudder is different than the rudder trim position, it is possible that the gyro will establish the fail-safe position as neutral instead of the trimmed neutral position. By making the rudder trim position and the fail-safe position the same, this is prevented from happening. In summary, after the helicopter is trimmed rebind the system to prevent the tail from drifting.

User Guide

This user guide is divided into two main sections: airplanes and helicopters. Blank data sheets are included at the end of each section. Once you have input all the necessary data for a particular model, it is recommended that you record that information on a data sheet. This insures that, in the rare case of a memory failure, you will not lose the data.

Note: Data sheets are available online that allow you to input, store and print data sheets for your convenience.

System Features

- Digital DSM™ Spread Spectrum Modulation
- 10-model memory
- Dual rates on aileron and elevator
- Exponential rates on aileron and elevator
- Dual and exponential rates can be combined on one switch
- Trainer system compatible with Spektrum™ and JR® radio systems.
- Adjustable stick length
- Throttle trim only affects idle position
- Two-speed scrolling
- Throttle-smart fail-safe system
- Digital trims for precise adjustment

Airplane Specific Features

- Aileron to rudder mixing
- Elevator-to-flap mixing
- Flap-to-elevator mixing
- Flaperon mixing
- Delta wing mixing
- Aileron differential
- V-tail mixing
- Three programmable mixes

Helicopter Specific Features

- Two 3-point throttle curves
- Three 3-point pitch curves
- Flight mode switch can combine throttle curves, pitch curves, dual and expo rates, and gyro sensitivity
- Throttle hold
- Revolution mixing up and down
- One programmable mix
- Supports 120° CCPM mixing
- Independent digital trim setting for each flight mode

AR6000 Receiver

- DualLink™ (pat pending) incorporates two receivers in one
- Ultralight 7 grams
- Compact design 39 x 39 x 9mm
- Smart fail-safe prevents motor start up if Tx is off and gives low throttle if signal is lost
- Short 3.75" antennas for mounting convenience
- Easy bind plug

Receiver Specifications

- Model#: AR6000
- Type: 6-channel parkflyer only
- Dimensions: 39 x 39 x 9mm
- Weight: 7 grams
- Frequency: 2.400–2.485
- Receiver antennas: 3.75"

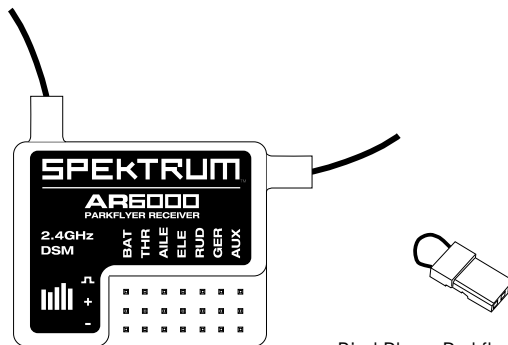

Bind Plug - Parkflyer Use Only
SPM6801

Servo Specifications

- Model #: SPMS75
- Dimensions: (LxWxH) 23 x 12 x 24mm
- Weight: 7.5 grams
- Torque: 17.2 oz @4.8V
- Speed: .12 sec @4.8V
- Operating voltage: 3.2–6.0V
- Motor type: Coreless

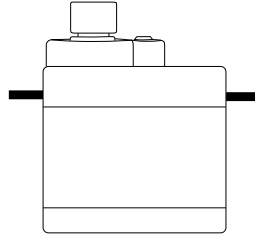
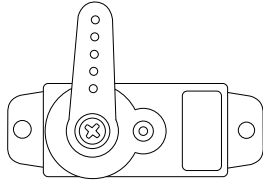

Charging the Transmitter

Transmitter

It is important to fully charge the transmitter battery prior to each flying session. The charger supplied with the system (SPM7105) is designed to recharge your transmitter battery at a rate of 50mA. For the initial charge, or if the transmitter hasn't been used for several months, it's important to charge the transmitter battery for 24 hours to achieve a full charge. Subsequent charges of 10–12 hours (approximately overnight) are recommended. Many modelers fast-charge their batteries. The DX6 does not have a charging diode in the circuit and will allow most fast chargers to be used, however, it is imperative to understand that all Spektrum™ transmitters have a center pin negative charge connector. When using an aftermarket charger, the charge plug must have the correct center pin negative polarity or damage can occur.

AFTER MARKET CHARGER PIGTAIL FOR TRANSMITTER

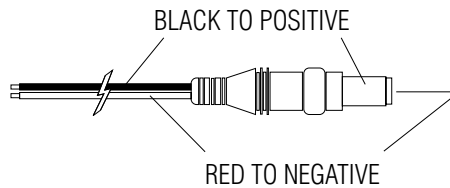

Important

The center pin on the DX6 transmitter is negative. Beware of improper connections based on “color code” wire leads, as they do not apply in this instance. When using aftermarket chargers, you must make certain that the center pin of your Spektrum transmitter is always connected to the negative polarity for correct hookup or damage can result.

RIGHT SIDE OF TRANSMITTER

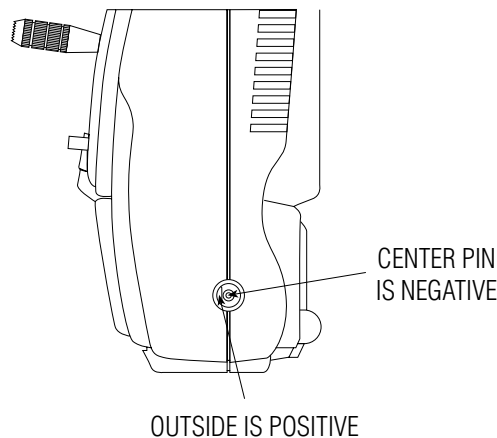

Trainer System

The DX6 features a built-in trainer system. The transmitter can be used as either a master (trainer) or as a slave (trainee). The DX6 is compatible with all other Spektrum™ and JR® radios that have built-in trainer systems. An optional Trainer Cord (SPM6805) is needed.

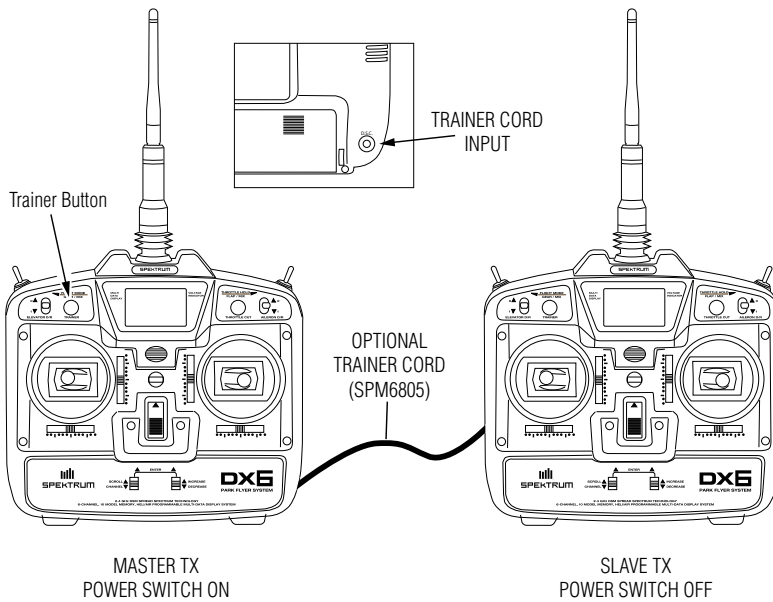

Operating the Trainer System

1. Match the servo reversing and trims of the master transmitter to the slave transmitter.
2. Plug the optional trainer cord into both transmitters.
3. Turn on the master transmitter.

Note: The slave radio must be left off.

4. Test all the control functions on your aircraft with the master radio.
5. Push the trainer button on the master transmitter and check all the control functions with the slave radio.

Control Identification and Location - Airplane

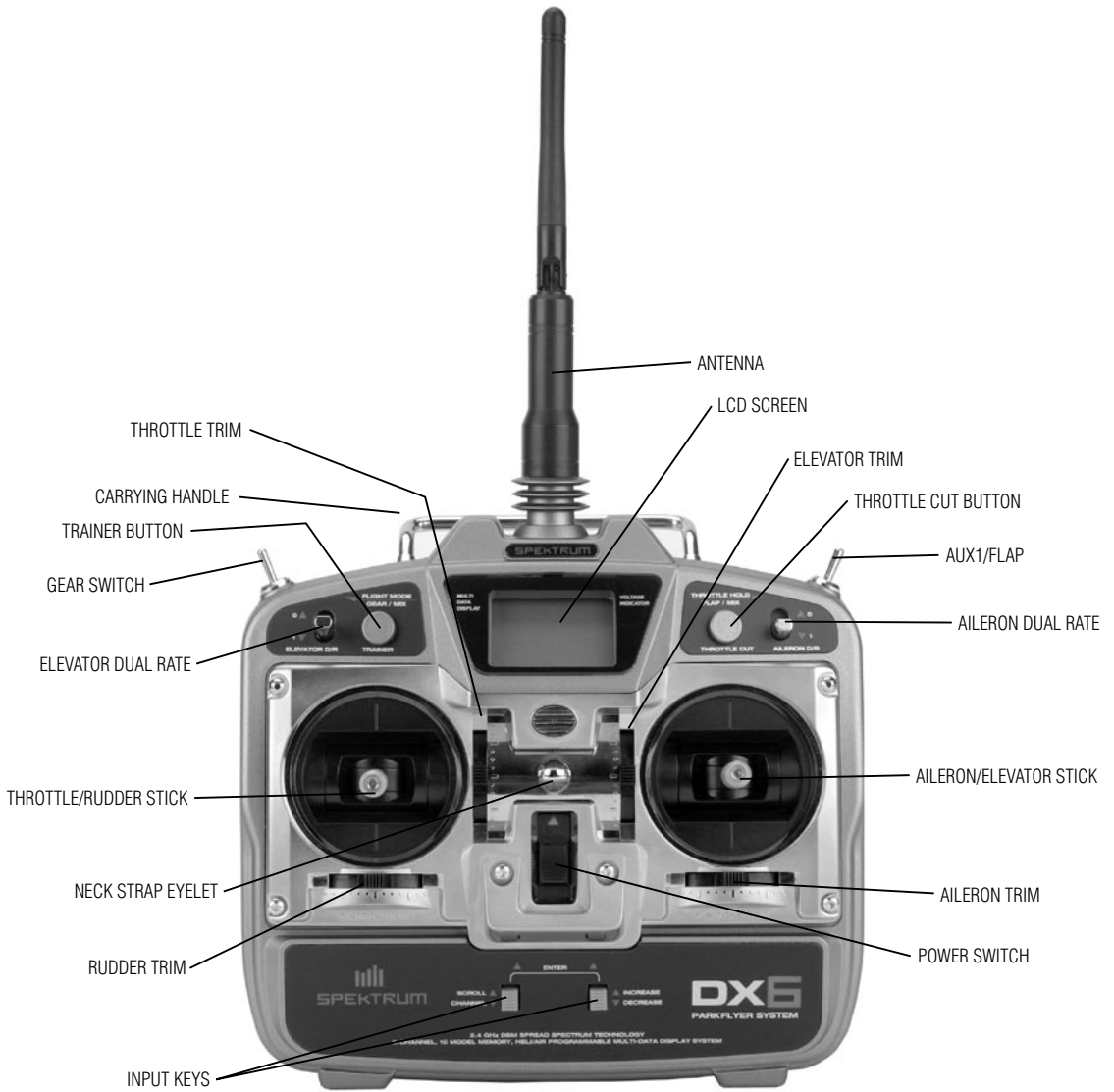

CHAPTER 1: TRANSMITTER CONTROLS

DIGITAL TRIM LEVERS



The DX6 features four digital trim levers with a direct trim display feature for ultra precise adjustments. When a trim input is given, the display screen will automatically change to show the trim value for current channel being adjusted. Once the trim change has been completed, the screen will automatically return to the previous screen display after 2–3 seconds.

A significant feature found only with Digital Trims is the ability for the DX6 to automatically store the trim values in system memory. This eliminates the need for previously found software functions like Trim Offset Memory (airplane), or Rudder Offset Memory and Stunt Trims (heli).

In Heli mode, the DX6's digital trims provide a separate set of trim values for each Flight mode (Normal, Stunt, and Throttle Hold), which takes the place of the previously needed Stunt Trim function. With this feature, the trim levers are active and independent in all flight modes, and will store the trim values for each mode independently. This feature also takes the place of the previously needed rudder offset function, since there is now a completely separate set of trim settings for the Throttle Hold mode.

RECEIVER CHANNEL ASSIGNMENT

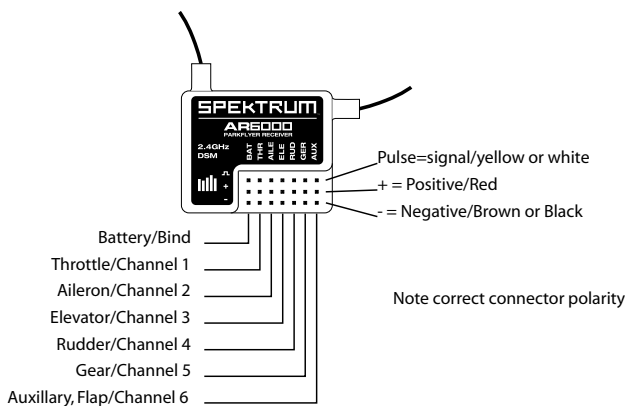

TRANSMITTER THROTTLE ALT

The Throttle ALT function makes the throttle stick trim active only when the throttle stick is less than half throttle. This gives easy, accurate idle adjustments without affecting the mid to high throttle position.

LITHIUM BATTERY

Note: The DX6 has a 5-year lithium battery to protect your programmed data against main transmitter battery failure. If your system displays “error” or your data resets to the factory defaults, return your transmitter to Horizon Service Center (see page 93) for lithium battery replacement.

CONTROL STICK LENGTH ADJUSTMENT

To adjust stick length, use a 2mm Allen wrench to loosen the setscrew located inside the end of the stick. Turn the setscrew counterclockwise to loosen then turn the knurled portion of the stick tip to adjust its length. When the desired length has been adjusted to suit your preference, tighten the setscrew.

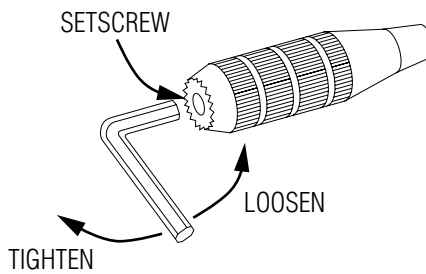

NECK STRAP ATTACHMENT

There is an eye hook on the front of the transmitter for attaching an optional neck strap.

RECEIVER ANTENNA MOUNTING

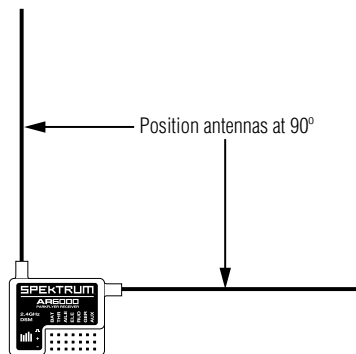

The AR6000 features dual receivers each with their own 3.75" antenna. While the antenna positions are relatively non-critical in most conditions, the ideal orientation is to have each antenna at nearly 90° to each other (see illustration). Tape can be used to fix the antennas in the desired positions.

RANGE TESTING

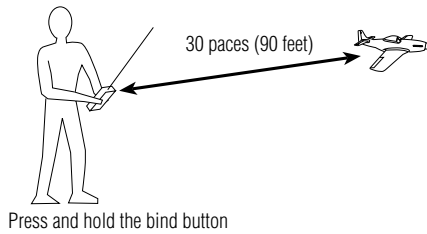

Before each flying session, and especially with a new model, it is important to perform a range check. The DX6 incorporates a system which, when the bind button on the back of the transmitter is pressed, the output power reduces allowing for a range check.

HOW TO RANGE TEST THE SYSTEM

1. With the model resting on the ground, stand 30 paces (approx. 90 feet) away from the model.
2. Face the model with the transmitter in your normal flying position and depress and hold the bind button on the back of the transmitter. This causes reduced power output from the transmitter.
3. You should have total control of the model with the button depressed at 30 paces.
4. If control issues exist call the Spektrum™ Service Center at 1-877-504-0233

BINDING

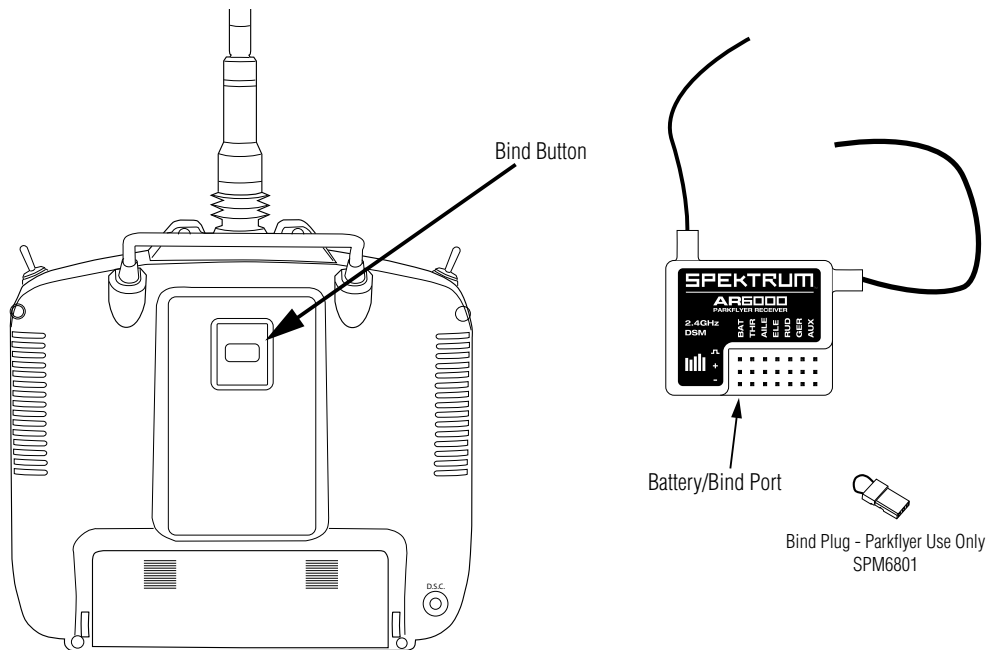

Each Spektrum™ transmitter has a GUID (Globally Unique Identifier) code. Binding is the process of programming the receiver to recognize the GUID of a single specific transmitter. Binding teaches the receiver the specific GUID of that transmitter, so that the receiver will only listen to the information from its previously bound transmitter and ignores everything else. With over 4.2 billion GUID codes the chances of having interference from another transmitter is virtually impossible. Fail-safe positions are set during binding, and usually it is only necessary to bind the receiver to the transmitter once. The only time it is necessary to rebind is if you wish to use a different transmitter or to change the fail-safe positions. Your AR6000 was bound to the transmitter during manufacturing however, if you wish to change to a different transmitter or change the throttle fail-safe position, the following process is necessary.

HOW TO BIND

1. With the power off, plug the bind plug into the BAT port.
2. Power on the receiver by connecting the battery to any unused port. The blue LED should be blinking.
3. Position the throttle stick in the desired fail-safe position (normally low throttle).
4. Press and hold the bind button on back of the transmitter while turning on the transmitter. The button should flash for about 5 seconds, then both LED's (transmitter and receiver) will go solid green.

Important: Remove the bind plug after binding.

SMART FAIL-SAFE

In case of loss of signal, the throttle will go to the preset position stored during binding. The other channels will hold last position. If the receiver is turned on before the transmitter, all channels but throttle will go to the fail-safe positions stored during binding, while the throttle will not generate a pulse so as not to affect the Electronic Speed Control.

CHAPTER 2: CONNECTIONS

CONNECTIONS

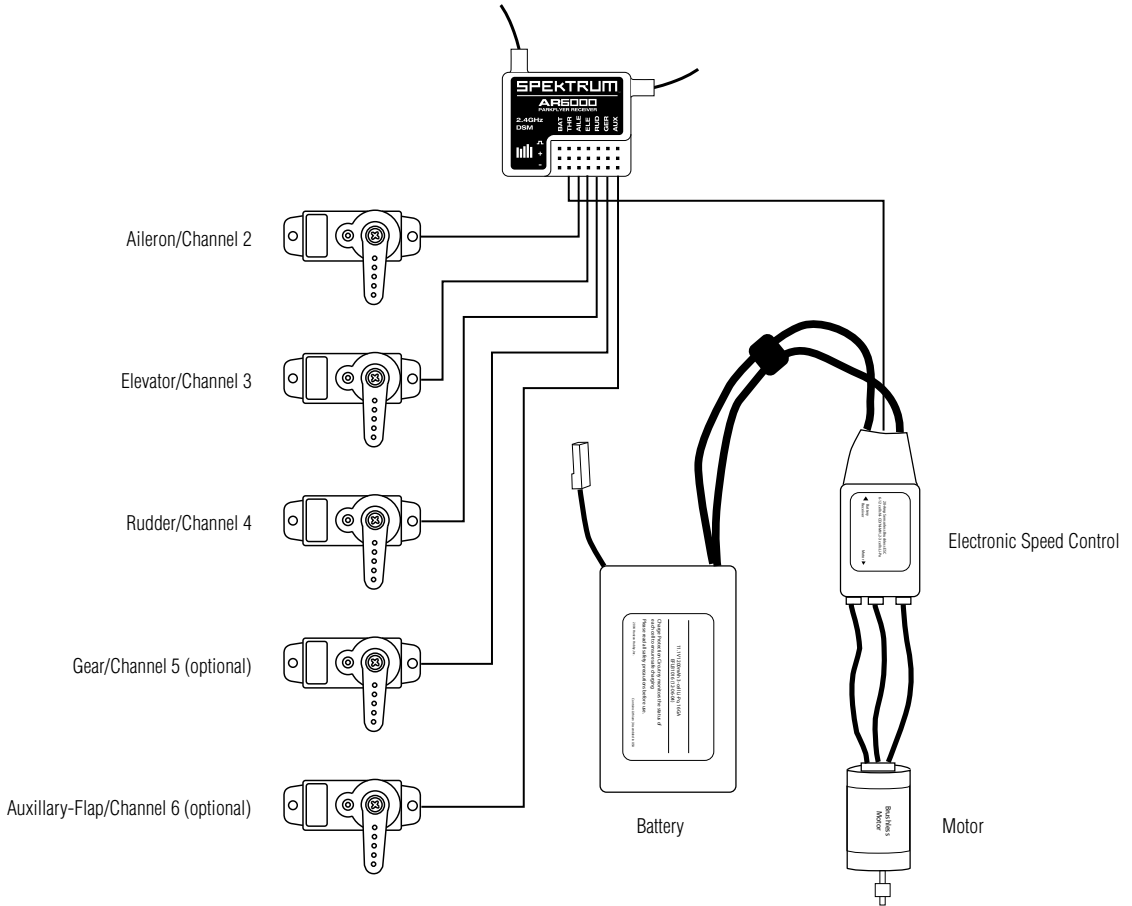

CHAPTER 3: KEY INPUT AND DISPLAY

Two input keys are located at the lower faceplate of the DX6 transmitter. The keys are used to access and program the transmitter. Each key can be moved up or down using your thumbs

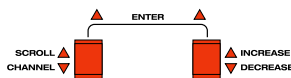

- | | | | |
|--------------------|--|---------------------|--|
| Left Button Up — | SCROLL — Used to advance through the menus | Right Button Up — | INCREASE — Increases value or changes setting (e.g., Reverse Normal) |
| Left Button Down — | CHANNEL — Used to advance through the channels or features in a given function | Right Button Down — | DECREASE — Decreases value or changes setting (e.g., Reverse Normal) |

CHAPTER 4: BATTERY ALARM AND DISPLAY

When the transmitter battery drops below 9.0 volts, the display will start to flash “BAT” and an audible alarm will sound eight times. This warning indicates a low battery condition and you should land your aircraft immediately.

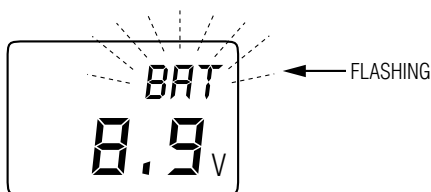

Note: During the period that the battery alarm is flashing, the input buttons will not function. If you are currently in the function mode, the transmitter will exit automatically and return to the normal display.

THROTTLE CUT

Your DX6 incorporates a special THROTTLE CUT function. The throttle cut button is located on the upper right face of the transmitter. This feature is designed primarily for glow-powered aircraft and is designed to shut off the engine when pressed without affecting the throttle trim position. With the throttle stick in the low position, pressing the throttle cut button will drive the throttle servo to its programmed low throttle, low trim endpoint adjusted in travel adjust. This will not be a commonly used feature for parkflyer aircraft.

Note: The Throttle Cut function is designed to function only when the throttle stick is below the 1/2 position.

CHAPTER 5: INPUT MODE AND FUNCTION

NORMAL DISPLAY

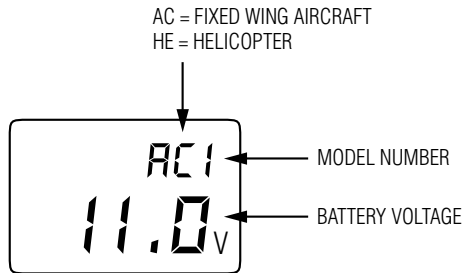

When the power switch is turned on, the screen will read as shown in the diagram. This screen is referred to as the normal display.

DIRECT TRIM ACCESS DISPLAY

The Direct Trim function of the DX6 can be accessed through the use of any of the four digital trims levers (throttle, aileron, elevator, or rudder).



When a trim input is given, the screen will automatically change to show the trim value for that particular channel. Once the trim adjustment has been made, the screen will automatically return to the previous screen setting after 2–3 seconds. The maximum trim value for each channel is +/- 40 in increments of 2.

SYSTEM MODE

To enter system mode, press the **SCROLL** and **INCREASE** buttons simultaneously upward while turning on the transmitter. You can now select any of 6 system mode functions shown here in the flow chart. Press the **SCROLL** button upward to move through the system mode functions. Information for each function is located on the page number listed next to the function name. To exit the system mode, press the **SCROLL** and **INCREASE** buttons upward simultaneously or turn off the transmitter.

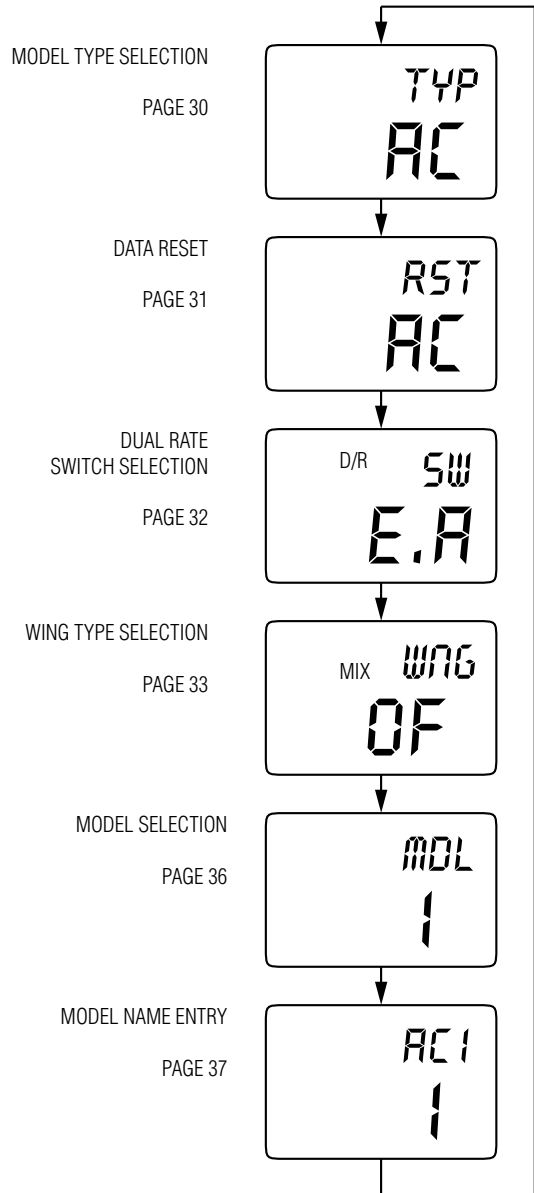

FUNCTION MODE

To enter the Function mode, turn on the transmitter. Press the **SCROLL** and **CHANNEL** buttons simultaneously upward until a beep is heard. The display will change accordingly and show the last active function. Press the Scroll button to scroll through the functions one by one as shown in the flowchart below. Once the appropriate function is selected, press the **CHANNEL** button downward to select the appropriate channel. Use the **INCREASE** and **DECREASE** buttons to adjust the values displayed on the screen.

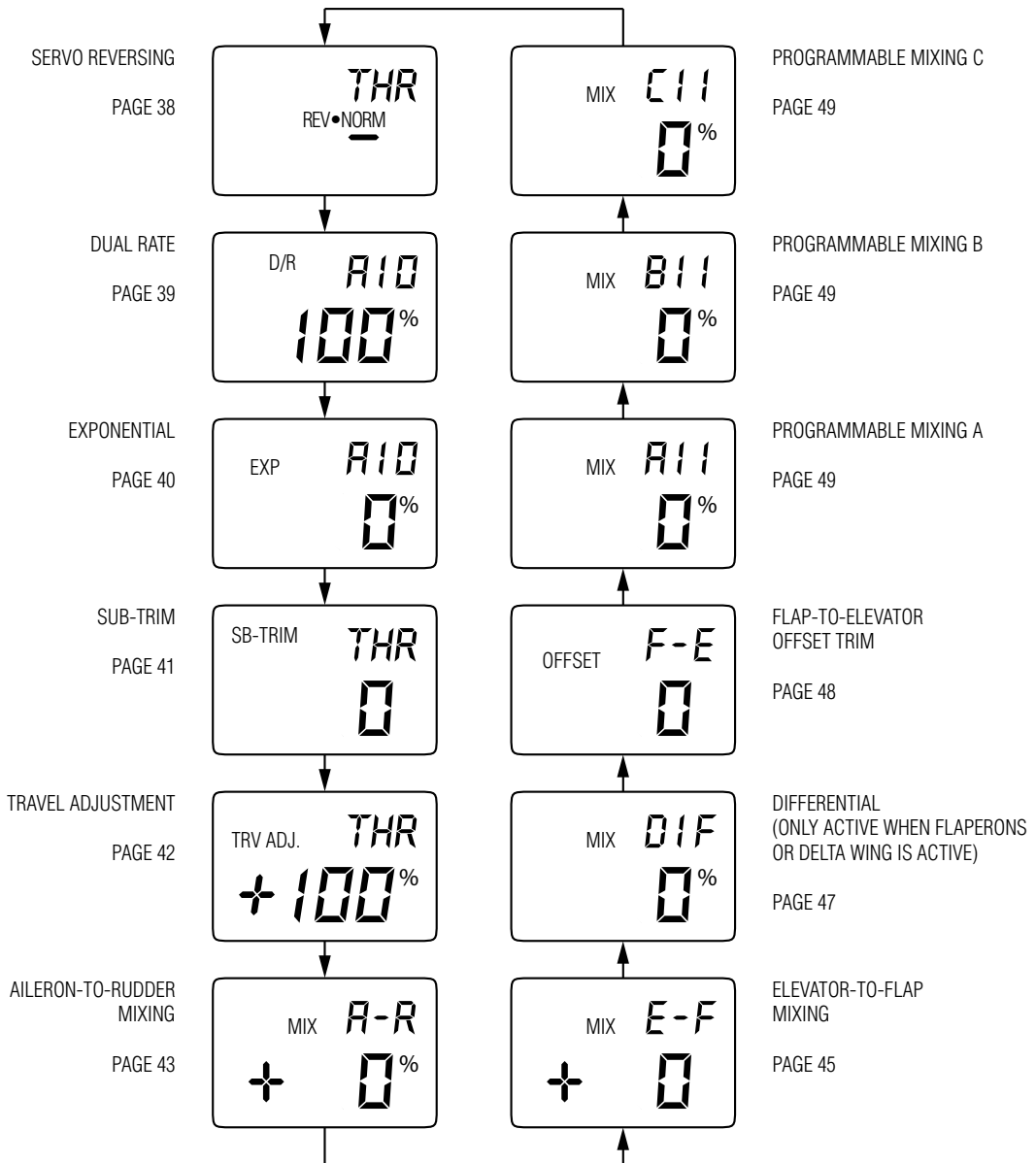

CHAPTER 6: FUNCTIONS (SYSTEM MODE)

MODEL TYPE SELECTION

Two types of aircraft programming are available with the DX6, airplane (AC) and helicopter (HE). When entering the model type selection function, the current model type will appear on the screen. (This will be the current model type set as the factory default or the last model used.) When you press the **INCREASE** or **DECREASE** button to change the model type, the new model type indicated on the screen will flash. For example, if the current model type is AC and you change to HE, "HE" will flash on the screen. The flashing alerts you to the change of model type and will stop once you move to the next function or exit the system mode.

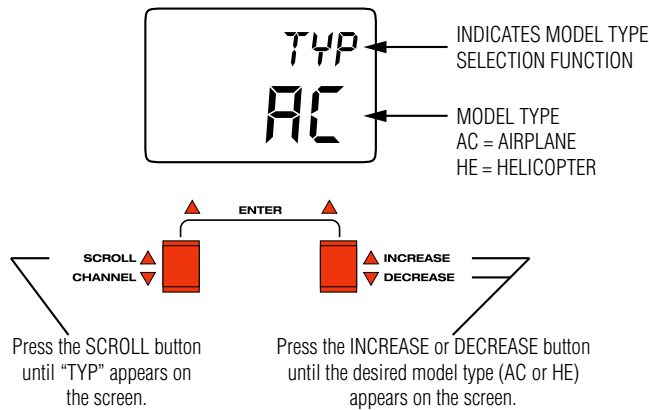

Note: When changing model types all programming will be reset to factory default settings.

ACCESSING THE MODEL TYPE SELECTION FUNCTION

1. Press the **SCROLL** and **INCREASE** buttons simultaneously and hold.
2. Turn on the transmitter to enter the system mode.
3. Press the **SCROLL** button until "TYP" appears on the screen.
4. Press the **INCREASE** or **DECREASE** button until the desired model type appears on the screen (AC = airplane HE = helicopter).
5. Press the **SCROLL** button to access the Data Reset function.
6. To exit, press the **SCROLL** and **INCREASE** buttons simultaneously.

DATA RESET

The data reset function allows you to reset all the programming in the current model selected (1–10) to the factory default settings. Before using the Data Reset function, it is important to enter the model selection function and select the desired model number (1–10) for which you want to reprogram to the factory settings. The model selection function is described on page 36.

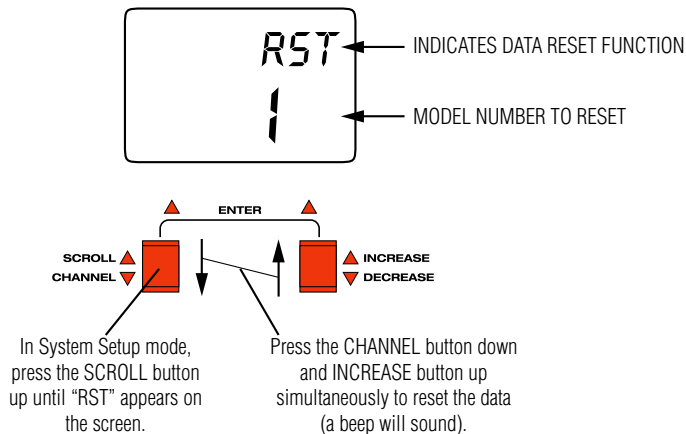

ACCESSING THE DATA RESET FUNCTION

1. Press the **SCROLL** and **INCREASE** buttons up simultaneously and hold.
2. Turn on the transmitter to enter the System mode.
3. Press the **SCROLL** button up until "RST" appears on the screen.
4. Press the **CHANNEL** and **INCREASE** buttons simultaneously to reset the data. (To confirm that the selected model's programming has been reset, a beep will sound and the model number will momentarily disappear from the screen.)
5. Press the **SCROLL** button to access the Model Select function.
6. To exit, press the **SCROLL** and **INCREASE** buttons up simultaneously.

DUAL RATE SWITCH SELECTION

The dual rate switch position is selectable and the elevator and aileron dual rates can be combined on one switch. This allows a single switch to be used when moving from high rates to low rates. Exponential Rate (EXP) is also available for both aileron and elevator and works in conjunction with the dual rate function to provide reduced sensitivity movements around neutral while allowing maximum servo travel. This reduces sensitivity in the middle portion of the stick control and still allows full travel at the end of the stick control. Refer to page 40 for exponential rate adjustment.

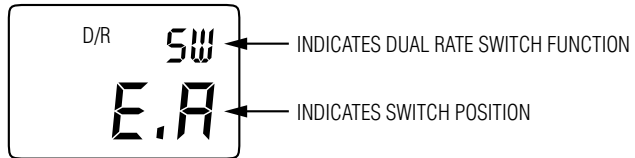

E.A = ELEVATOR AND AILERON OPERATE INDIVIDUALLY
A. = OPERATION OF ELEVATOR AND AILERON DUAL RATE ON AILERON DUAL RATE SWITCH
E. = OPERATION OF ELEVATOR AND AILERON DUAL RATE ON ELEVATOR DUAL RATE SWITCH
CF = COMBINED FUNCTION OPERATION OF ELEVATOR AND AILERON DUAL RATE ON GEAR/MIX SWITCH

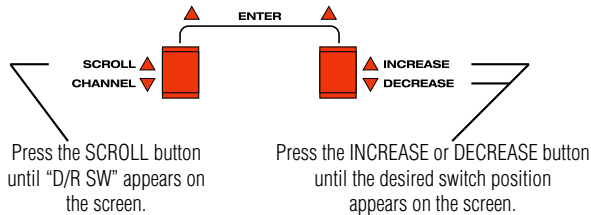

Note: For an easy method to add dual rate rudder, see Programming a Rudder Dual Rate page 53. Refer to page 40 for exponential rate adjustment.

ACCESSING THE DUAL RATE SWITCH SELECTION FUNCTION

1. Press the **SCROLL** and **INCREASE** buttons simultaneously and hold.
2. Turn on the transmitter to enter the system mode.
3. Press the **SCROLL** button until "D/R SW" appears on the screen.
4. Press the **INCREASE** or **DECREASE** button until the desired switch position appears on the screen. (E.A, A., E. or CF)
5. Press the **SCROLL** button to access the Wing Type selection function.
6. To exit, press the **SCROLL** and **INCREASE** buttons simultaneously.

WING TYPE SELECTION

Flaperon, V-tail, and Delta Mixing are available for aircraft that require these functions. The flaperon feature is used when two servos are located in the wing, one to control each aileron plus this function allows the ailerons to be drooped or raised while still functioning fully as ailerons. V-Tail Mixing combines rudder and elevator for V-Tail operations. The Delta Wing function allows the aileron to also act as the elevator, while retaining independent use of both functions. The Delta Wing function allows the ailerons to also act as the elevator, while retaining independent use of both functions.

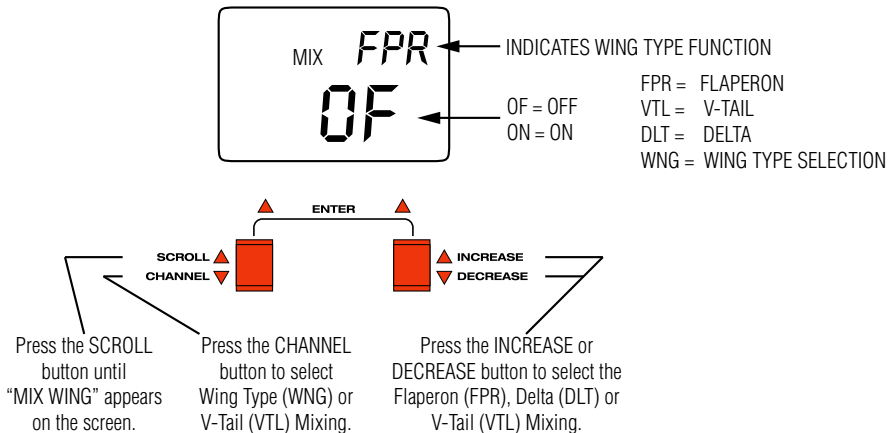

ACCESSING THE WING TYPE SELECTION FUNCTION

1. Press the **SCROLL** and **INCREASE** buttons up simultaneously and hold.
2. Turn on the transmitter to enter the System mode.
3. Press the **SCROLL** button until the "MIX WNG" appears on the screen.
4. Press the **CHANNEL** button to select either the Wing Type (WNG) or V-Tail (VTL) mode.
5. Press the **SCROLL** button to access the Model Name function.
6. To exit, press the **SCROLL** and **INCREASE** buttons up simultaneously.

FLAPERON SETUP

Flaperon mixing is used with airplanes that have independent servos operating each of the two ailerons. When using flaperon mixing, two servos (one for each aileron) must be used. Once FPN is selected in wing type the following will help in setting up flaperons.

- Connect the left aileron servo to channel #6 (AUX) and the right aileron servo to channel #2 (AILE) in the receiver.
- In the travel adjust mode (see page 42) adjust the travel adjust values for flap to 0% in both directions. This will effectively turn off the flap switch for now, preventing the flaperons (both ailerons combined) from moving up or down when the flap switch is flipped. Later by assigning a value in either direction the flap switch can be used to raise or lower the flaps.

Note: Individual functions (e.g., servo reversing, sub-trims, dual rates, etc.) are still available for each of the aileron and flap channels. Use sub-trims for individual neutral adjustment. Adjust the ailerons travel values by increasing or decreasing the aileron travel adjust. D/R and expo values, as well as differential, are also available in the appropriate screens.

WING TYPE SELECTION (CONTINUED)

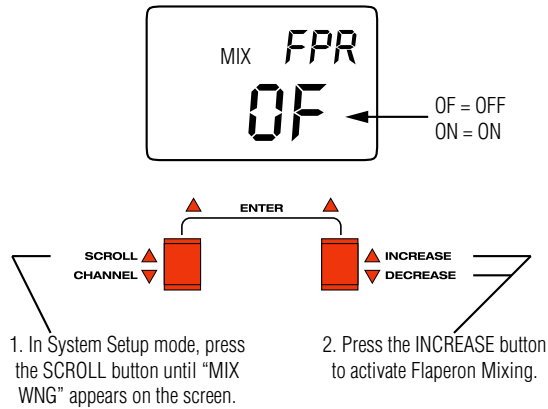

TO ACTIVATE FLAPERON (FPR) MIXING (WING TYPE MODE)

1. In System Setup mode, press the **SCROLL** button until "MIX WNG" appears on the screen.
2. Press the **INCREASE** button to activate Flaperon Mixing.

V-TAIL

V-Tail Mixing requires two servos, each connected to the right and left tail control surfaces. Connect the left tail servo to channel #3 (ELE) and the right tail servo to channel #4 (RUD) in the receiver. Individual functions (e.g., servo reversing, sub-trims, etc.) are available for each servo. Use sub-trims for individual neutral adjustments and to vary the up and down travel as desired by using the dual rate function to adjust elevator vs. rudder travel independently.

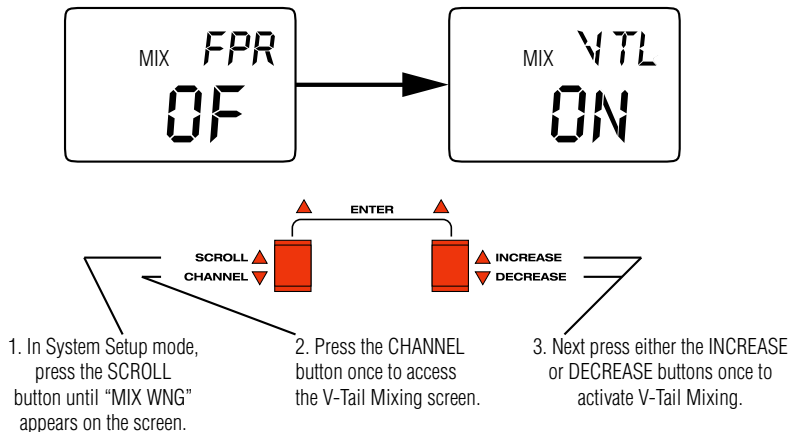

TO ACTIVATE V-TAIL (VTL) MIXING

1. In System Setup mode, press the **SCROLL** button until "MIX WNG" appears on the screen.
2. Press the **CHANNEL** button once to access the V-Tail Mixing screen.
3. Next press either the **INCREASE** or **DECREASE** buttons once to activate V-Tail Mixing.

Note: It is also possible to activate both the Flaperon (FPR) and V-Tail (VTL) functions to work simultaneously. While it is unlikely to have an aircraft that would require both, it is possible.

WING TYPE SELECTION (CONTINUED)

DELTA-WING MIXING

Delta or Elevon Mixing is designed for flying wing type airplanes and employs two servos in the wing to control two trailing edge control surfaces for pitch and roll control. Elevator stick inputs will cause the two wing servos to function in conjunction with one another in the same direction to create an up/down movement of both surfaces to control pitch. The aileron stick control movements will cause the two wing servos to move in opposite directions to function as ailerons for roll control.

Connect the left tail servo to channel #3 (ELE) and the right tail servo to channel #2 (AILE) in the receiver. Individual functions (e.g., servo reversing, sub-trims, etc.) are available for each servo. Use sub-trims for individual neutral adjustments and using the dual rate function to vary the elevator vs. rudder travel can be independently adjusted.

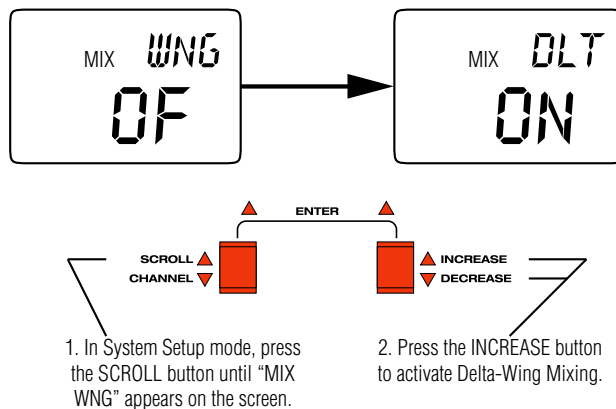

TO ACTIVATE DELTA-WING (DLT) MIXING (WING TYPE MODE)

1. In System Setup mode, press the **SCROLL** button until "MIX WNG" appears on the screen.
2. Press the **DECREASE** button to activate Delta-Wing Mixing.

MODEL SELECTION

The DX6 has memory for ten models. It can store the settings for ten airplanes, ten helicopters, or any combination of both types of models.

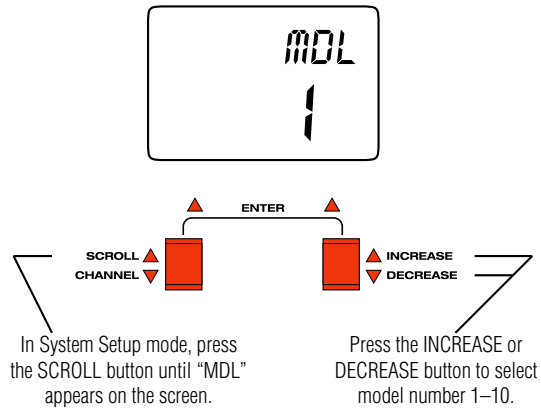

ACCESSING THE MODEL SELECTION FUNCTION

1. Press the **SCROLL** and **INCREASE** buttons upward simultaneously and hold.
2. Turn on the transmitter to enter the system mode.
3. Press the **SCROLL** button until "MDL" appears on the screen.
4. Press the **INCREASE** or **DECREASE** button to select model number 1 through 10.
5. Press the **SCROLL** button to access the Model Name entry function.
6. To exit, press the **SCROLL** and **INCREASE** buttons simultaneously.

MODEL NAME ENTRY

The DX6 allows a three-digit name to be input for each of the ten models available. The current model will be displayed in the normal display. This feature helps identify different aircraft types or model setups.

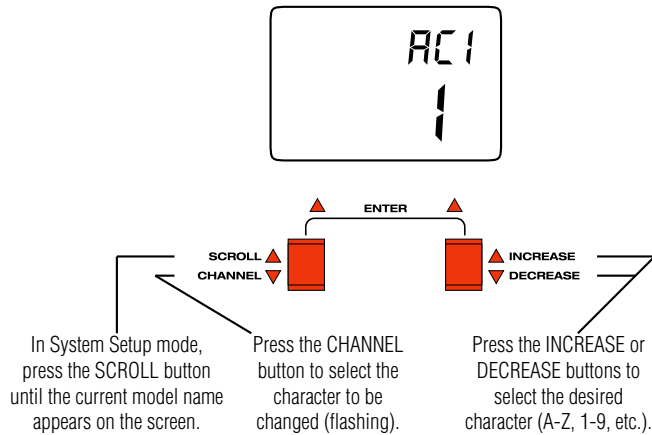

ACCESSING THE MODEL NAME ENTRY FUNCTION

1. Press the **SCROLL** and **INCREASE** buttons simultaneously and hold.
2. Turn on the transmitter to enter the System mode.
3. Press the **SCROLL** button until the current model or "AC1" appears on the screen.
4. Press the **INCREASE** or **DECREASE** buttons to select the correct letter/number for the first character (flashing).
5. To adjust the remaining two characters, press the **CHANNEL** button until the desired character to be adjusted is flashing.
6. Press the **SCROLL** button to access the Modulation Select function.
7. To exit, press the **SCROLL** and **INCREASE** buttons simultaneously.

CHAPTER 7: FUNCTIONS (FUNCTION MODE)

SERVO REVERSING

Servo reversing is a convenient function used in the setup of a new aircraft. It is used to change the direction of servo rotation in relation to the corresponding stick movement. Servo reversing is available for all six channels.

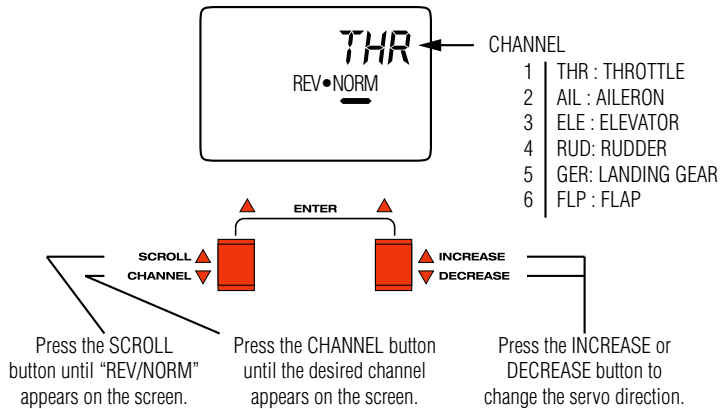

ACCESSING THE SERVO REVERSING FUNCTION

1. Turn on the transmitter.
2. Press the **SCROLL** and **INCREASE** buttons simultaneously to enter the function mode.
3. Press the **SCROLL** button until "REV-NORM" appears on the screen.
4. Press the **CHANNEL** button until the desired channel appears on the screen.
5. Press the **INCREASE** or **DECREASE** button to change the servo direction.
6. Press the **SCROLL** button to access the Dual Rate function.
7. To exit, press the **SCROLL** and **CHANNEL** buttons simultaneously.

DUAL RATE

Different types of maneuvers require varying amounts of control movements. Snap rolls require large control movements, while smooth maneuvers like long slow rolls are best performed with smaller control movements. Dual rates allow you to change the control movements in flight at the flip of a switch. This allows you to execute maneuvers requiring both radical control movements and small control movements during a single flight.

Dual rate is available for the aileron and elevator channels. The amount of travel is adjustable from 0-125%. The factory settings for both switch positions (0 and 1) are 100%. Either position may be selected as the low or high rate by placing the switches in the desired position and adjusting the value for that position.

Note: For an easy method to add dual rate rudder see mixing page 53.

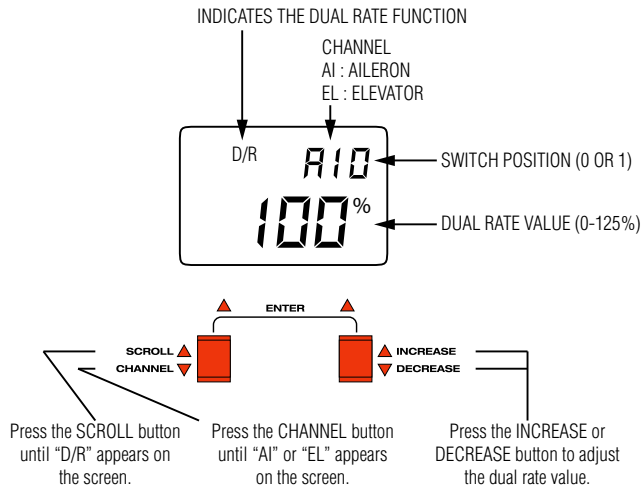

ACCESSING THE DUAL RATE FUNCTION

1. Turn on the transmitter.
2. Press the **SCROLL** and **INCREASE** buttons simultaneously to enter the function mode.
3. Press the **SCROLL** button until "D/R" appears on the screen.
4. Press the **CHANNEL** button until the desired channel appears on the screen (A1 = Aileron or EL = Elevator).
5. The number that appears directly to the right of the selected channel is the switch position. There are two switch positions, 0 and 1, for each of the channels. A "0" will appear when the selected dual rate switch is in the uppermost position and a "1" when the selected switch is in the lower position.
6. To change the switch selection you must enter the dual rate switch selection function in the System Mode (see page 32).
7. The number in the center of the screen indicates the current dual rate value for the selected switch position and channel. Press the **INCREASE** or **DECREASE** button to adjust the dual rate value (0–125%).
8. After adjusting the value for the 0-switch position, change to the 1-switch position and adjust the rates.
9. Press the **CHANNEL** button to select the other channel and adjust the dual rate value for both switch positions.
10. Press the **SCROLL** button to access the Exponential Rate feature.
11. To exit, press the **SCROLL** and **INCREASE** buttons simultaneously.

EXPONENTIAL

Programmable exponential adjustments are offered on the aileron and elevator channels on the DX6 system. Exponential is a function that allows you to tailor the response rate of the controls as compared to the stick inputs. The purpose of exponential is to reduce the sensitivity in the middle portion of stick movement, while still allowing full travel at the end of the stick movement. The adjustable range of the Exponential function is from 0–100%. Zero percent (0%) is linear stick control which means that the response rate is equal throughout the stick control. One hundred percent (100%) is full exponential. The larger the exponential value, the less servo action, or sensitivity, you will notice around the neutral setting.

Note: The Exponential function operates in conjunction with the Dual Rate function. It is imperative to understand the Dual Rate function prior to adjusting the exponential values. Exponential may be selected independently for either the high or low rate (position 0 or 1) or both.

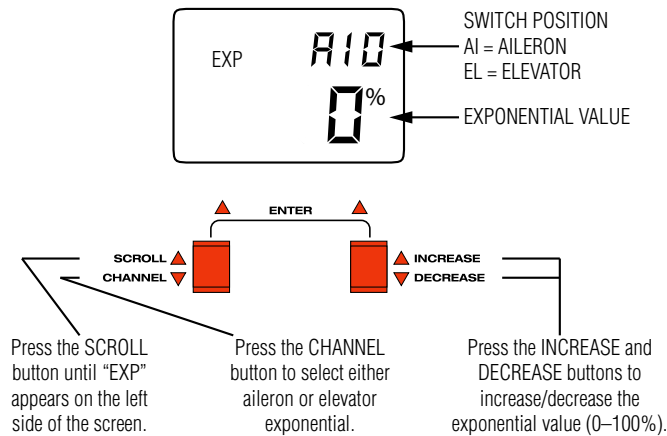

ACCESSING THE EXPONENTIAL FUNCTION

1. Turn on the transmitter.
2. Press the **SCROLL** and **INCREASE** buttons simultaneously to enter the Function mode.
3. Press the **SCROLL** button until "EXP" appears at the left side of the screen.
4. Press the **CHANNEL** button until the desired channel appears on the screen (AI or EL).
5. Using the appropriate dual rate switch, select the correct position to be adjusted (0 or 1).
6. Press the **INCREASE** or **DECREASE** buttons to INCREASE/DECREASE the exponential value.
7. Press the **SCROLL** button to access the Sub-Trim function.
8. To exit, press the **SCROLL** and **INCREASE** buttons simultaneously.

SUB-TRIM

Sub-trim is an electronic trim that is available for each of the six channels. Sub-trim is particularly useful to precisely neutralize the servo position electronically, when it difficult to achieve the desired position mechanically.

Note: It is recommended to use as little Sub trim value as possible for adjustment. If more that 20–30 points are required, it is suggested that a mechanical linkage adjustment be performed at the servo by rotating the servo horn to the next spline and re-adjusting the linkage.

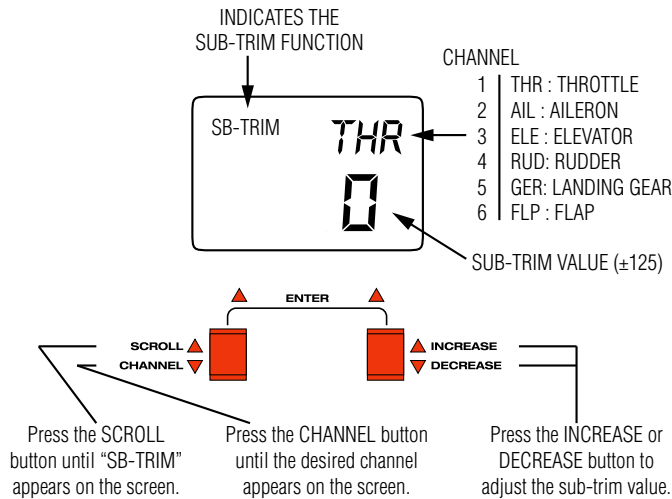

ACCESSING THE SUB-TRIM FUNCTION

1. Turn on the transmitter.
2. Press the **SCROLL** and **INCREASE** buttons simultaneously to enter the function mode.
3. Press the **SCROLL** button until "SB-TRIM" appears on the screen.
4. Press the **CHANNEL** button until the desired channel appears on the screen.
5. Press the **INCREASE** or **DECREASE** button to establish the desired amount of sub-trim.
6. Press the **SCROLL** button to access the travel adjustment function.
7. To exit, press the **SCROLL** and **INCREASE** buttons simultaneously.

TRAVEL ADJUSTMENT

The amount of servo travel is adjustable in each direction independently for each of the six channels. The adjustment range is from 0% to 150%. Travel adjustment is factory set at 100% for all channels. The travel adjustment value direction displayed on the screen coincides with the position of the stick or switch (e.g., flap switch, gear switch). This function is useful to adjust control surface travel without the need for mechanical adjustment.

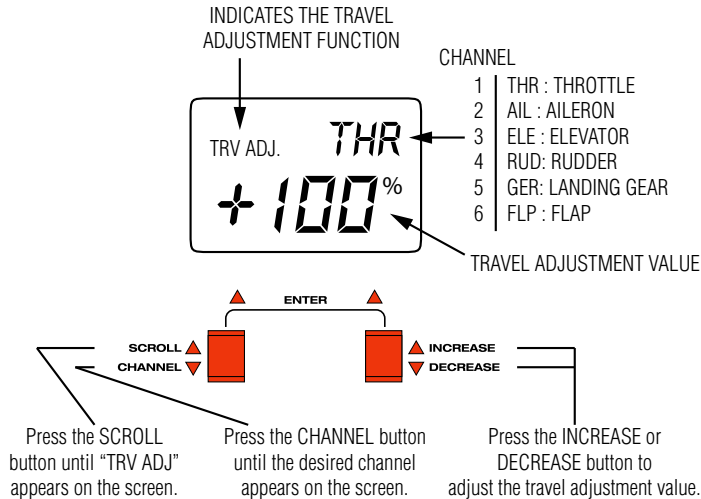

ACCESSING THE TRAVEL ADJUSTMENT FUNCTION

1. Turn on the transmitter.
2. Press the **SCROLL** and **INCREASE** buttons simultaneously to enter the function mode.
3. Press the **SCROLL** button until "TRV ADJ." appears on the screen.
4. Press the **CHANNEL** button until the desired channel appears on the screen.
5. Move the selected channel stick or switch in the direction that you want to adjust the travel. Press the **INCREASE** or **DECREASE** button to achieve the desired travel. Move the stick in the opposite direction to adjust the travel in the opposite direction.
6. The same may be done for all channels.
7. Press the **SCROLL** button to access the aileron- to-rudder mixing function.
8. To exit, press the **SCROLL** and **INCREASE** buttons simultaneously.

AILERON-TO-RUDDER MIXING

On some types of aircraft, it is desirable to mix aileron and rudder to make coordinated turns. The DX6 allows the mixing of aileron-to-rudder and allows you to adjust the amount and direction of aileron to rudder mixing. The aileron-to-rudder mixing can be left on all the time or it can be turned off with the selection of one of three switches on page 32.

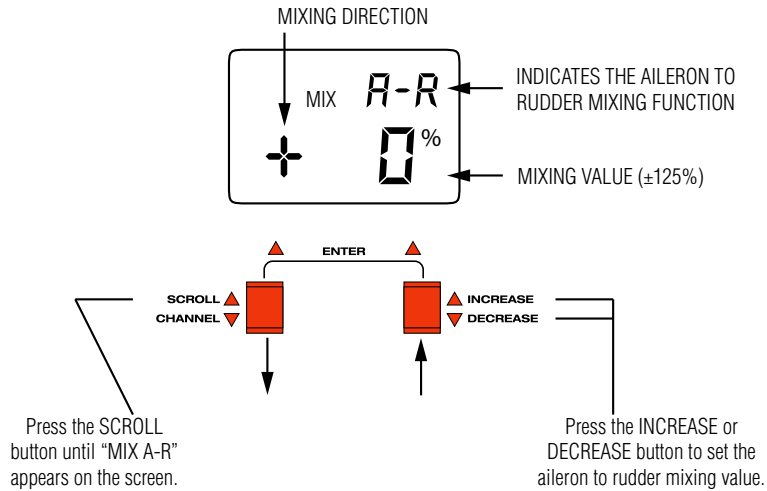

ACCESSING THE AILERON-TO-RUDDER MIXING FUNCTION

1. Turn on the transmitter.
2. Press the **SCROLL** and **INCREASE** buttons simultaneously to enter the Function mode.
3. Press the **SCROLL** button until "MIX A-R" appears on the screen.
4. Press the **CHANNEL** and **INCREASE** button to set the desired amount and direction of aileron-to-rudder mixing.

Note: If "OF" appears on the screen, it is because the aileron to rudder mixing switch is in the off position.

AILERON-TO-RUDDER MIXING SWITCH SELECTION

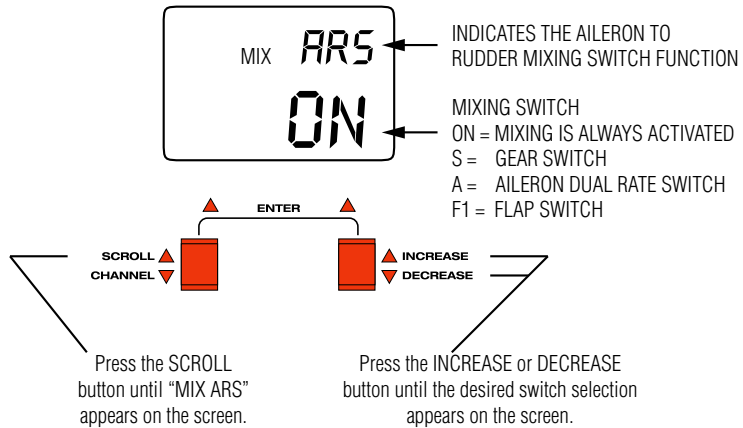

ACCESSING THE AILERON-TO-RUDDER MIXING SWITCH FUNCTION

1. Press the **CHANNEL** button until "MIX ARS" appears on the screen.
2. Press the **INCREASE** or **DECREASE** button until the desired switch selection appears on the screen.
3. Press the **SCROLL** button to access the elevator-to-flap mixing function.
4. To exit, press the **SCROLL** and **INCREASE** buttons simultaneously.

ELEVATOR-TO-FLAP MIXING

Elevator-to-flap mixing in opposite directions (elevator up and flaps down) is commonly used to increase the pitch rate of an aircraft. This is commonly used in fun fly airplanes. Mixed in the same direction (elevator up, flaps up) it prevents tip stalling in high alpha maneuvers. This is very popular with 3D airplanes.

This function can be always be left on, or turned off and on, via one of three selectable switches. See page 46 for more on Elevator-to-Flap mixing.

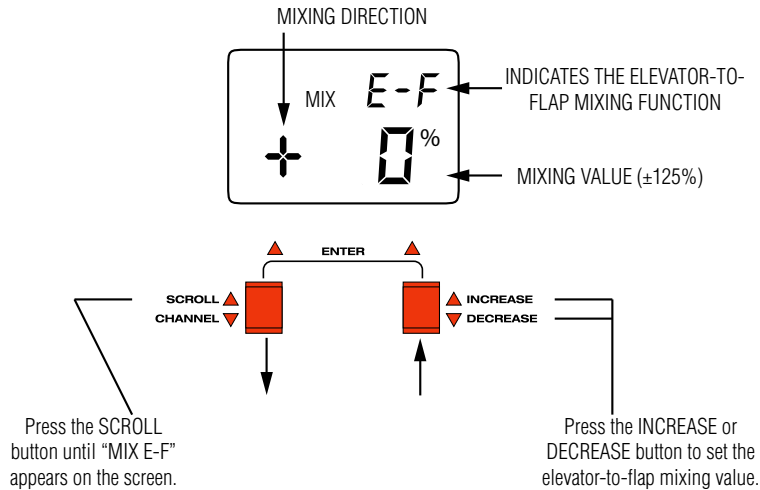

ACCESSING THE ELEVATOR-TO-FLAP MIXING FUNCTION

1. Turn on the transmitter.
2. Press the **SCROLL** and **INCREASE** buttons simultaneously to enter the function mode.
3. Press the **SCROLL** button until "MIX E-F" appears on the screen.
4. Press the **CHANNEL** and **INCREASE** buttons simultaneously to set the elevator-to-flap mixing direction.
5. Press the **INCREASE** or **DECREASE** button to set the elevator-to-flap mixing value.

ELEVATOR-TO-FLAP MIXING SWITCH SELECTION

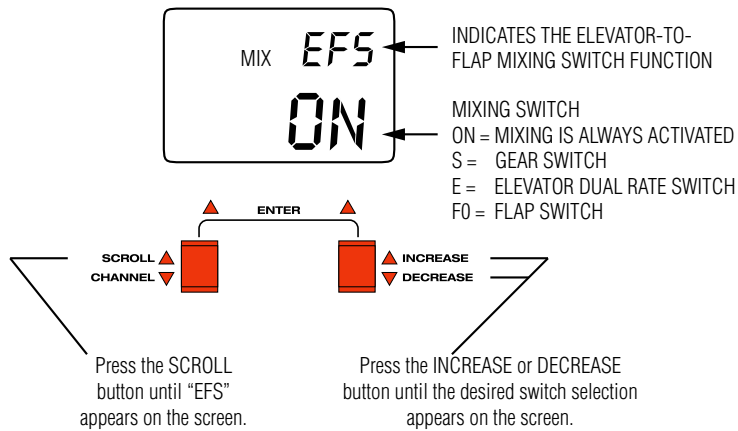

ACCESSING THE ELEVATOR-TO-FLAP MIXING SWITCH FUNCTION

1. Press the **CHANNEL** button until "MIX EFS" appears on the screen.
2. Press the **INCREASE** or **DECREASE** button until the desired switch designation appears on the screen.
3. Press the **SCROLL** button to access the differential function if flaperons or delta-wing types are activated in the system mode. If flaperons are not activated, pressing the **SCROLL** button will access the flap-to-elevator offset function.
4. To exit, press the **SCROLL** and **INCREASE** buttons simultaneously.

DIFFERENTIAL

Aileron differential is used to correct roll to yaw coupling and adverse yaw characteristics during rolling maneuvers. In order to activate differential, the flaperon or Delta wing type must be selected in the system mode (see page 35). Also, each aileron control surface must have its own servo with the right aileron servo plugged into the aileron channel (#2) on the receiver and the left aileron servo plugged into the Flap Aux 1 channel (#6) on the receiver.

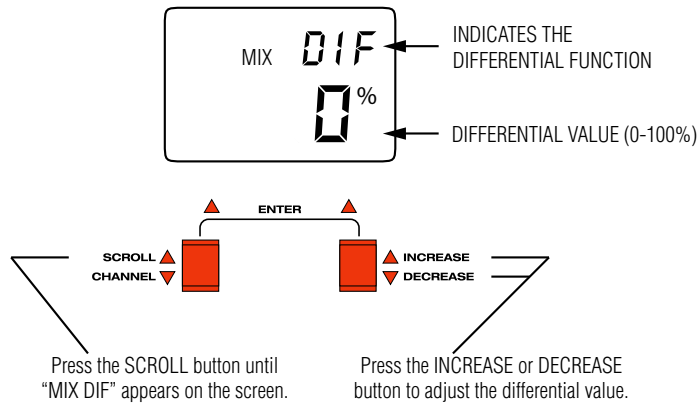

ACCESSING THE DIFFERENTIAL FUNCTION • FLAPERON/DELTA MODE ONLY

1. Turn on the transmitter.
2. Flaperon wing type must be selected (see page 33).
3. Press the **SCROLL** and **INCREASE** buttons simultaneously to enter the function mode.
4. Press the **SCROLL** button until "MIX DIF" appears on the screen.
5. Press the **INCREASE** or **DECREASE** button to adjust the differential mixing value.
6. Press the **SCROLL** button to access the flap-to-elevator offset trim function.
7. To exit, press the **SCROLL** and **INCREASE** buttons simultaneously.

FLAP-TO-ELEVATOR OFFSET TRIM

When the flaps are deployed, most airplanes exhibit pitching tendencies (most pitch nose up with down flap). Elevator offset trim is designed to prevent this pitching. Flap-to-elevator offset trim automatically changes the elevator trim to a preset value when the flap switch is activated.

Note: Flap-to-elevator offset trim is also useful as a dual elevator trim even for airplanes without flaps. This is especially helpful for sailplanes that require one trim setting for launch and another trim setting for flight.

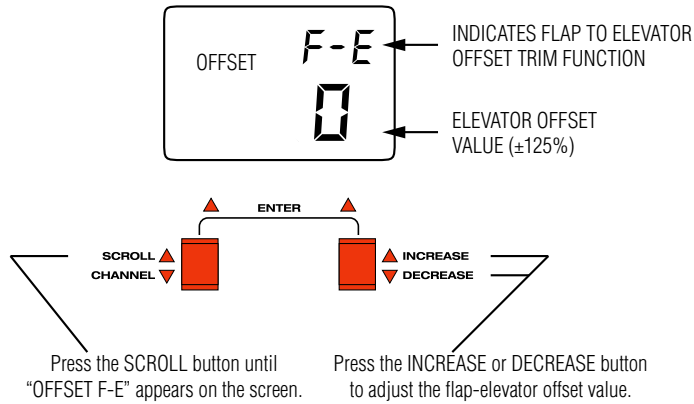

ACCESSING THE FLAP-TO-ELEVATOR OFFSET TRIM FUNCTION

1. Turn on the transmitter.
2. Press the **SCROLL** and **INCREASE** buttons simultaneously to enter the function mode.
3. Press the **SCROLL** button until "OFFSET F-E" appears on the screen.
4. Press the **INCREASE** or **DECREASE** button to set the desired amount and direction of the elevator offset.

Note: It is helpful to have the flap switch on when making this adjustment.

5. Press the **SCROLL** button to access the Programmable Mix function.
6. To exit, press the **SCROLL** and **INCREASE** buttons simultaneously.

PROGRAMMABLE MIXING (A, B, C)

In airplane mode, the DX6 offers three programmable mixes (A, B, and C) allowing numerous mixing options. This function allows mixing any one channel to any other channel. The mix can remain ON at all times, or be switched ON/ OFF in flight using a number of different switches. Each channel is identified by channel numbers 1-6 (i.e., 2 = aileron, 4 = rudder, etc.). The channel appearing first is known as the “master channel,” or the channel to which you want to mix. The second channel is known as the “slave channel” or the channel that is being mixed into the master channel. For example, “2/4” would indicate aileron-to-rudder mixing. Each time the aileron stick is moved, the aileron will deflect, and the rudder will automatically move in the direction and to the value input that is programmed. Mixing is proportional, so small inputs of the master channel will produce small outputs of the slave channel. Each programmable mix has a mixing “offset.” The purpose of the mixing offset is to redefine the neutral position of the slave channel.

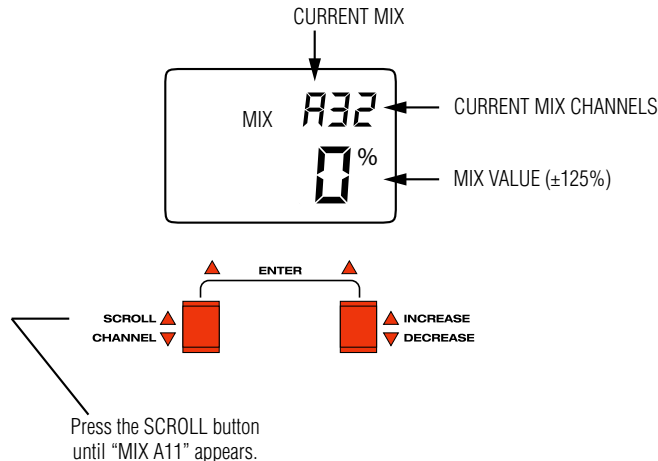

ACCESSING THE PROGRAMMABLE MIXING FUNCTION

1. Turn on the transmitter.
2. Press the **SCROLL** and **INCREASE** buttons simultaneously to enter the Function mode.
3. Press the **SCROLL** button until “MIX A11” appears at the top right corner of the screen. This is Program Mix A. Pressing the **SCROLL** button again will select mixes B and C.

PROGRAMMABLE MIXING (A, B, C) (CONTINUED)

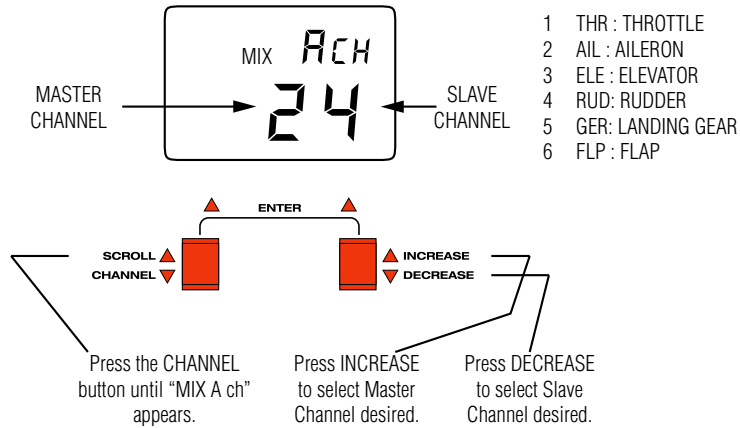

ASSIGNING CHANNELS

1. Press the channel button twice until "MIX A CH" appears on the screen.
2. Press the **INCREASE** button to select the desired Master Channel (1-6).
3. Press the **DECREASE** button to select the desired Slave Channel (1-6).

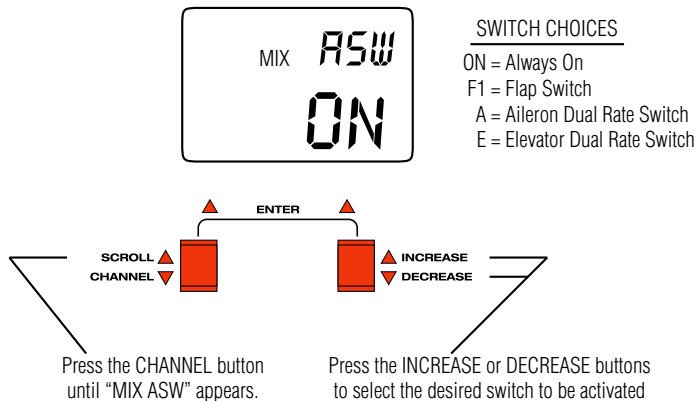

SWITCH SELECTION

1. Press the **CHANNEL** button once until "MIX ASW" appears.
2. Press the **INCREASE** or **DECREASE** button to select the switch to be used to activate the mixing, or leave on if a constant mix is desired.

PROGRAMMABLE MIXING (A, B, C) (CONTINUED)

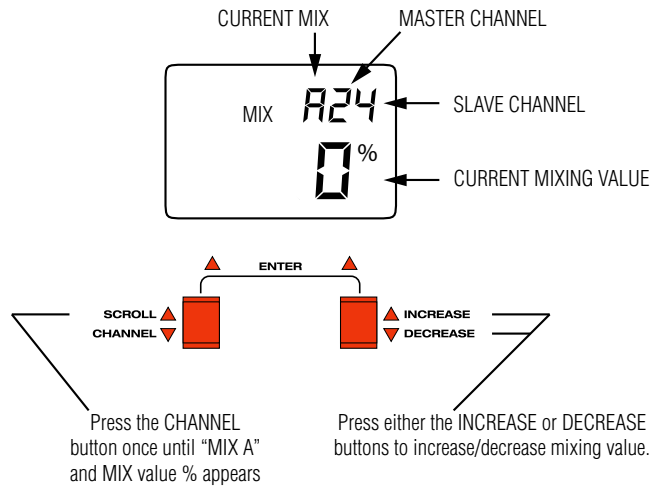

MIXING VALUE ADJUSTMENT

1. Press the **CHANNEL** button once until "MIX A" appears, with the mixing value located at the bottom of the screen.
2. To set the slave channel's mixing value, move and hold the master channel control stick to the direction to be adjusted (up/down—left/right), then press the **INCREASE** key to add positive mixing value, or the **DECREASE** key to add negative mixing value (+/-125%). When the master channel's stick is moved, the display will automatically show the mixing value for the current stick direction.

Note: If a mix switch position other than "ON" is selected, it will be necessary to move the selected switch to the on (or active) position to adjust the mixing value. "OF" will appear on the screen if the selected mixing switch is in the off position.

OFFSET

MIXING OFFSET ADJUSTMENT

The purpose of the mixing offset feature is to redefine the neutral position of the slave channel to be mixed. Any desired position may be selected for the offset reference point. To set the offset position, Place the master channel's stick to the desired position and press either the **INCREASE** or **DECREASE** keys.

This position is now stored in the memory and its offset value from the neutral position of the master channel is indicated numerically on the LCD display.

Then, the mixing value at the determined offset position is now set at 0.

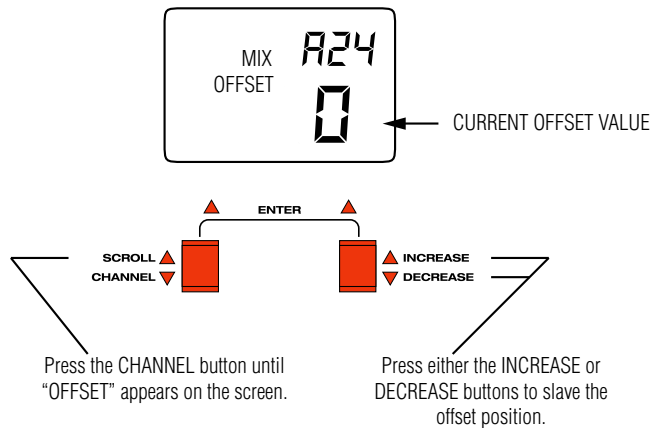

ACCESSING THE OFFSET FUNCTION

1. Press the **CHANNEL** button once until Mix Offset appears in the center of the screen.
2. Place the master channel stick to the desired offset position, then press either the **INCREASE** or **DECREASE** button to store the offset. The offset value will be displayed.
3. Press the **SCROLL** button once to access Program Mix B, press twice to access program MIX C, and a third time for servo reversing.
4. To exit the Function mode, press the **SCROLL** and **INCREASE** buttons simultaneously.

Note: If a mix switch position other than on has been selected, it will be necessary to move the selected switch to the on or active position to set the offset value. "OF" will appear on the screen if the selected mixing switch is in the off position.

PROGRAMMING A RUDDER DUAL RATE

Programmable mixing is a powerful feature that offers many creative options. As an example, a dual rate rudder can be easily added and turned on/off via a selected switch. By mixing rudder-to-rudder, (4-4) selecting the desired switch to turn on/off the mix and by assigning positive values to increase the rudder travel, or negative values to reduce the travel a rudder dual rate is added that offers independent throw values in each direction. Following are the steps to add a rudder dual rate:

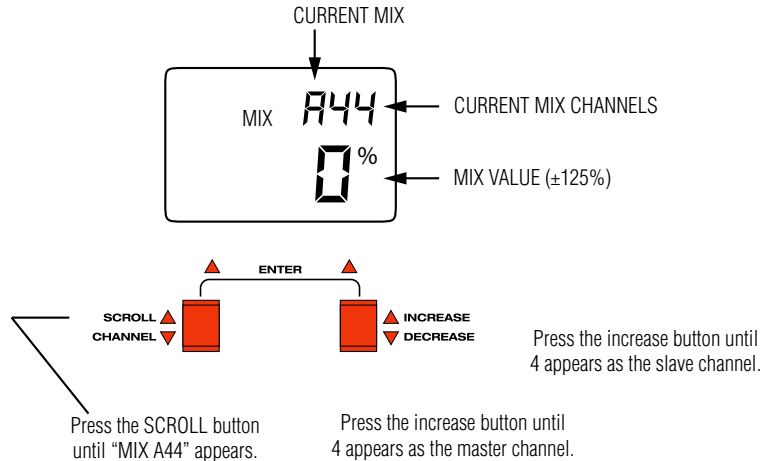

PROGRAMMING A RUDDER DUAL RATE

1. Turn on the transmitter.
2. Press the **SCROLL** and **INCREASE** buttons simultaneously to enter function mode.
3. Press the **SCROLL** button until mix "A11" appears at the top right corner of the screen.
4. Press the **INCREASE** button until 4 (rudder) appears on the screen as the master channel.
5. Press the **DECREASE** button until 4 (rudder) appears on the screen as the slave channel.
6. Move the rudder stick in the desired direction and press the **INCREASE** or **DECREASE** button to set the desired rudder dual rate travel.

Note: A positive value increases the rudder travel, while a negative value decreases the rudder travel.

7. Move the rudder stick in the opposite direction to adjust that direction's value.



SWITCH CHOICES

ON = Always On
F1 = Flap Switch
A = Aileron Dual Rate Switch
E = Elevator Dual Rate Switch

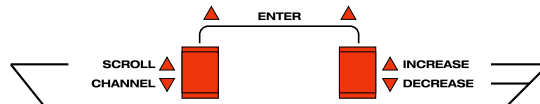

Press the **CHANNEL** button until "MIX ASW" appears.

Press the **INCREASE** or **DECREASE** buttons to select the desired switch to be activated

SWITCH SELECTION

1. Press the **CHANNEL** button once until "MIX ASW" appears.
2. Press the **INCREASE** or **DECREASE** button to select the switch to be used to activate the mixing, or leave on if a constant mix is desired.

CHAPTER 8: Data Sheet

MODEL NUMBER _____

MODEL NAME _____

CHANNELS	THRO (1)	AIL (2)	ELE (3)	RUDD (4)	GER (5)	AUX1 (6)
REVERSE SW	NORM • REV	NORM • REV	NORM • REV	NORM • REV	NORM • REV	NORM • REV
SUB-TRIM						
TRAVEL ADJUST (TRV ADJ)	+ %	+ %	+ %	+ %	+ %	+ %
	- %	- %	- %	- %	- %	- %
%						

D/R SW	EA • A • E • CF
--------	-----------------

LANDING ELEV OFFSET	±
---------------------	---

WING TYPE	NORM • FLAPERON • DELTA
V-TAIL	ON • OFF
DIFFERENTIAL	%

DUAL RATE • EXP			AIL (AI)	ELEV (EL)
	POS 0	D/R	%	%
		EXP	%	%
	POS 1	D/R	%	%
EXP		%	%	

	MIX SW	POS
AIL ⇔ RUDD MIX	ON • F • A • E	%
ELEV ⇔ FLAP MIX	ON • F • A • E	%

PROG. MIX		CHANNEL MASTER ⇔ SLAVE	MIX SWITCH	OFFSET	+GAIN	-GAIN
	A	⇔	ON • F • A • E			
	B	⇔	ON • F • A • E			
	C	⇔	ON • F • A • E			

CHAPTER 1: TRANSMITTER CONTROLS

DIGITAL TRIM LEVERS



The DX6 features four digital trim levers with a direct trim display feature for ultra precise adjustments. When a trim input is given, the display screen will automatically change to show the trim value for current channel being adjusted. Once the trim change has been completed, the screen will automatically return to the previous screen display after 2–3 seconds.

A significant feature found only with Digital Trims is the ability for the DX6 to automatically store the trim values in system memory. This eliminates the need for previously found software functions like Trim Offset Memory (airplane), or Rudder Offset Memory and Stunt Trims (Heli).

In Heli mode, the DX6's digital trims provide a separate set of trim values for each Flight mode (Normal, Stunt, and Throttle Hold), which takes the place of the previously needed Stunt Trim function. With this feature, the trim levers are active and independent in all flight modes, and will store the trim values for each mode independently. This feature also takes the place of the previously needed rudder offset function, since there is now a completely separate set of trim setting for the Throttle Hold mode.

RECEIVER CHANNEL ASSIGNMENT

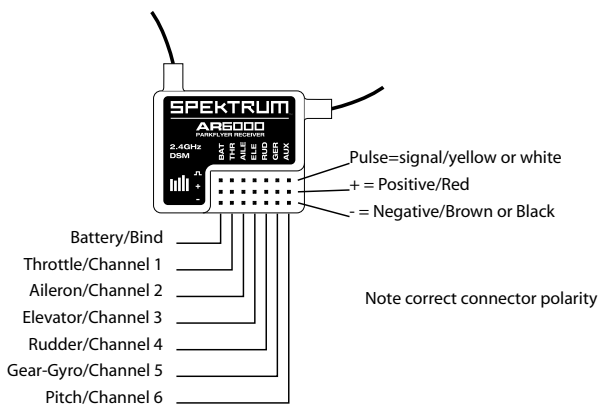

TRANSMITTER THROTTLE ALT

The Throttle ALT function makes the throttle stick trim active only when the throttle stick is less than half throttle. This gives easy, accurate idle adjustments without affecting the mid to high throttle position.

LITHIUM BATTERY

Note: The DX6 has a 5-year lithium battery to protect your programmed data against main transmitter battery failure. If your system displays “error” or your data resets to the factory defaults, return your transmitter to Horizon Service Center (see page 93) for lithium battery replacement.

CONTROL STICK LENGTH ADJUSTMENT

To adjust stick length, use a 2mm Allen wrench to loosen the setscrew located inside the end of the stick. Turn the setscrew counterclockwise to loosen then turn the knurled portion of the stick tip to adjust its length. When the desired length has been adjusted to suit your preference, tighten the setscrew.

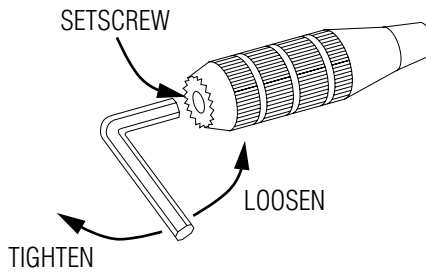

NECK STRAP ATTACHMENT

There is an eye hook on the front of the transmitter for attaching an optional neck strap.

RECEIVER ANTENNA MOUNTING

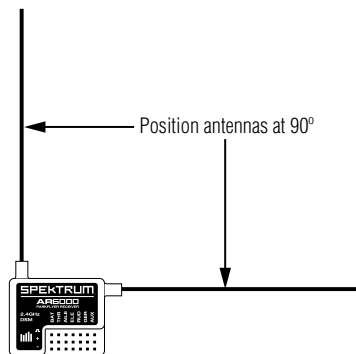

The AR6000 features dual receivers each with their own 3.75" antenna. While the antenna positions are relatively non-critical in most conditions, the ideal orientation is to have each antenna at nearly 90° to each other (See illustration). Tape can be used to fix the antennas in the desired positions.

RANGE TESTING

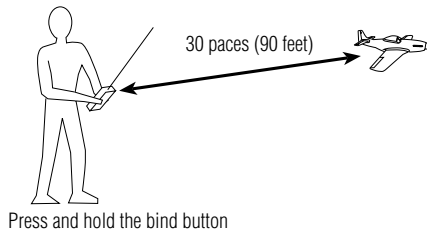

Before each flying session and especially with a new model, it is important to perform a range check. The DX6 incorporates a system which when the bind button on the back of the transmitter is pressed, the output power is reduced allowing for a range check.

HOW TO RANGE TEST THE SYSTEM

1. With the model resting on the ground, stand 30 paces (approx. 90 feet) away from the model.
2. Face the model with the transmitter in your normal flying position and depress and hold the bind button on the back of the transmitter. This causes reduced power output from the transmitter.
3. You should have total control of the model with the button depressed at 30 paces.
4. If control issues exist call the Spektrum™ service center at 1-877-504-0233.

BINDING

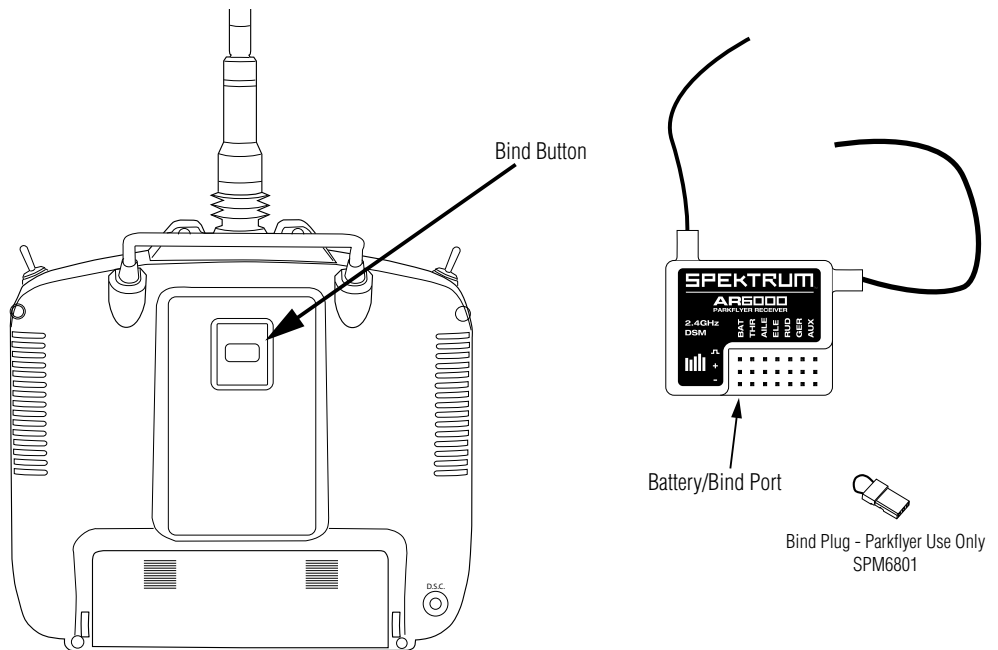

Each Spektrum™ transmitter has a GUID (Globally Unique Identifier) code. Binding is the process of programming the receiver to recognize the GUID of a single specific transmitter. Binding teaches the receiver the specific GUID of that transmitter so that the receiver will only listen to the information from its previously bound transmitter and ignores everything else. With over 4.2 billion GUID codes the chances of having interference from another transmitter is virtually impossible. Fail-safe positions are set during binding and usually it is only necessary to bind the receiver to the transmitter once. The only time it is necessary to re-bind is if you wish to use a different transmitter or to change the fail-safe positions. Your AR6000 was bound to the transmitter during manufacturing, however, if you wish to change to a different transmitter or change the throttle fail-safe position the following process is necessary.

HOW TO BIND

1. With the power off, plug the bind plug into the BAT port.
2. Power on the receiver by connecting the battery to any unused port. The blue LED should be blinking.
3. Position the throttle stick in the desired fail-safe position (normally low throttle).
4. Press and hold the bind button on back of the transmitter while turning on the transmitter. The button should flash for about 5 seconds then both LED's (transmitter and receiver) will go solid green.

Important: Remove the bind plug after binding.

SMART FAIL-SAFE

In case of loss of signal, the throttle will go to the preset position stored during binding. The other channels will hold last position. If the receiver is turned on before the transmitter, all channels but throttle will go to the fail-safe positions stored during binding while the throttle will not generate a pulse so as not to affect the Electronic Speed Control.

CHAPTER 2: CONNECTIONS

CONNECTIONS

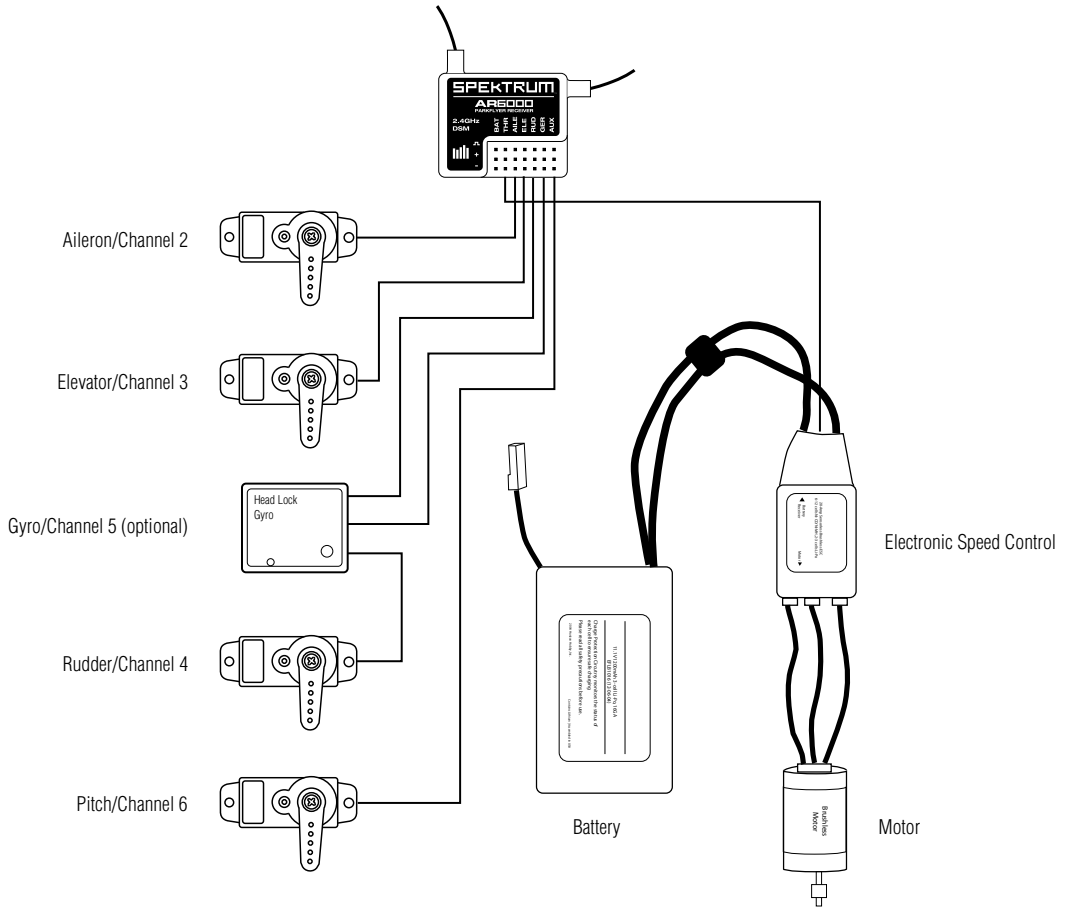

CHAPTER 3: KEY INPUT AND DISPLAY

KEY INPUT AND DISPLAY

Two input keys are located at the lower faceplate of the DX6 transmitter. The keys are used to access and program the transmitter. Each key can be moved up or down using your thumbs

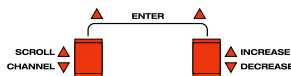

Left Button Up — SCROLL — Used to advance through the menus

Left Button Down — CHANNEL — Used to advance through the channels or features in a given function

Right Button Up — INCREASE — Increases value or changes setting (e.g., Reverse Normal)

Right Button Down — DECREASE — Decreases value or changes setting (e.g., Reverse Normal)

CHAPTER 4: BATTERY ALARM AND DISPLAY

When the transmitter battery drops below 9.0 volts, the display will start to flash “BAT” and an audible alarm will sound eight times. This warning indicates a low battery condition and you should land your aircraft immediately.

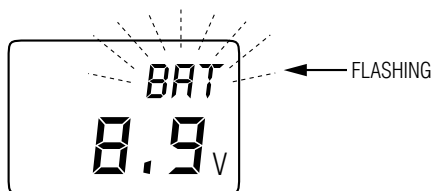

Note: During the period that the battery alarm is flashing, the input buttons will not function. If you are currently in the function mode, the transmitter will exit automatically and return to the normal display.

THROTTLE CUT

Your DX6 incorporates a special THROTTLE CUT Function. The throttle cut button is located on the upper right face of the transmitter. This feature is designed primarily for glow-powered aircraft and is designed to shut off the engine when pressed without affecting the throttle trim position. With the throttle stick in the low position, pressing the throttle cut button will drive the throttle servo to its programmed low throttle, low trim endpoint adjusted in travel adjust. This will not be a commonly used feature for parkflyer aircraft.

Note: The Throttle Cut function is designed to function only when the throttle stick is below the 1/2 position.

CHAPTER 5: INPUT MODE AND FUNCTION

NORMAL DISPLAY

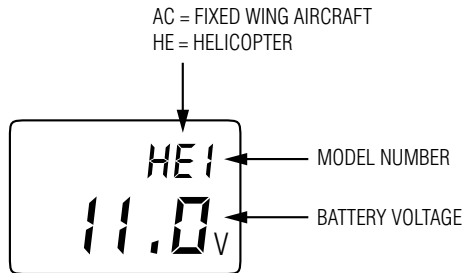

When the power switch is turned on, the screen will read as shown here in the diagram. This screen is referred to as the normal display.

DIRECT TRIM ACCESS DISPLAY

The Direct Trim function of the DX6 can be accessed through the use of any of the four digital trims levers (throttle, aileron, elevator, or rudder).



When a trim input is given, the screen will automatically change to show the trim value for that particular channel. Once the trim adjustment has been made, the screen will automatically return to the previous screen setting after 2–3 seconds. The maximum trim value for each channel is +/- 40 in increments of 2.

SYSTEM MODE

To enter system mode, press the **SCROLL** and **INCREASE** buttons simultaneously upward while you turn on the transmitter. You can now select any of 6 system mode functions shown here in the flow chart. Press the **SCROLL** button upward to move through the system mode functions. Information for each function is located on the page number listed next to the function name. To exit the system mode, press the **SCROLL** and **INCREASE** buttons upward simultaneously or turn off the transmitter.

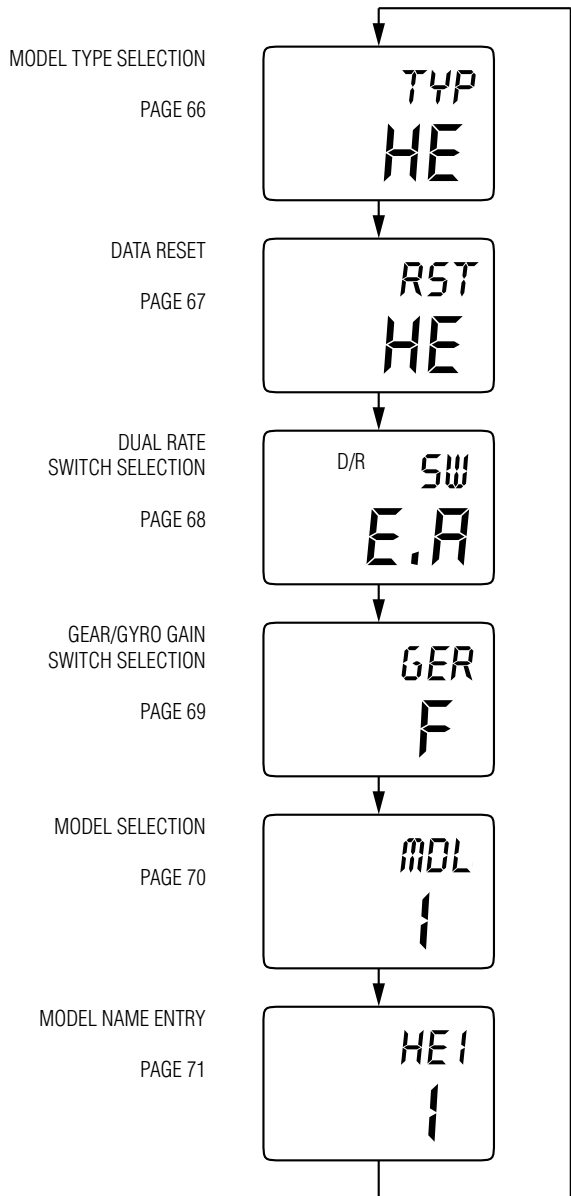

FUNCTION MODE

To enter the Function mode, turn on the transmitter. Press the **SCROLL** and **CHANNEL** buttons simultaneously upward until a beep is heard. The display will change accordingly and show the last active function. Press the **SCROLL** button to **SCROLL** through the functions one by one as shown in the flowchart below. Once the appropriate function is selected, press the **CHANNEL** button downward to select the appropriate channel. Use the **INCREASE** and **DECREASE** buttons to adjust the values displayed on the screen.

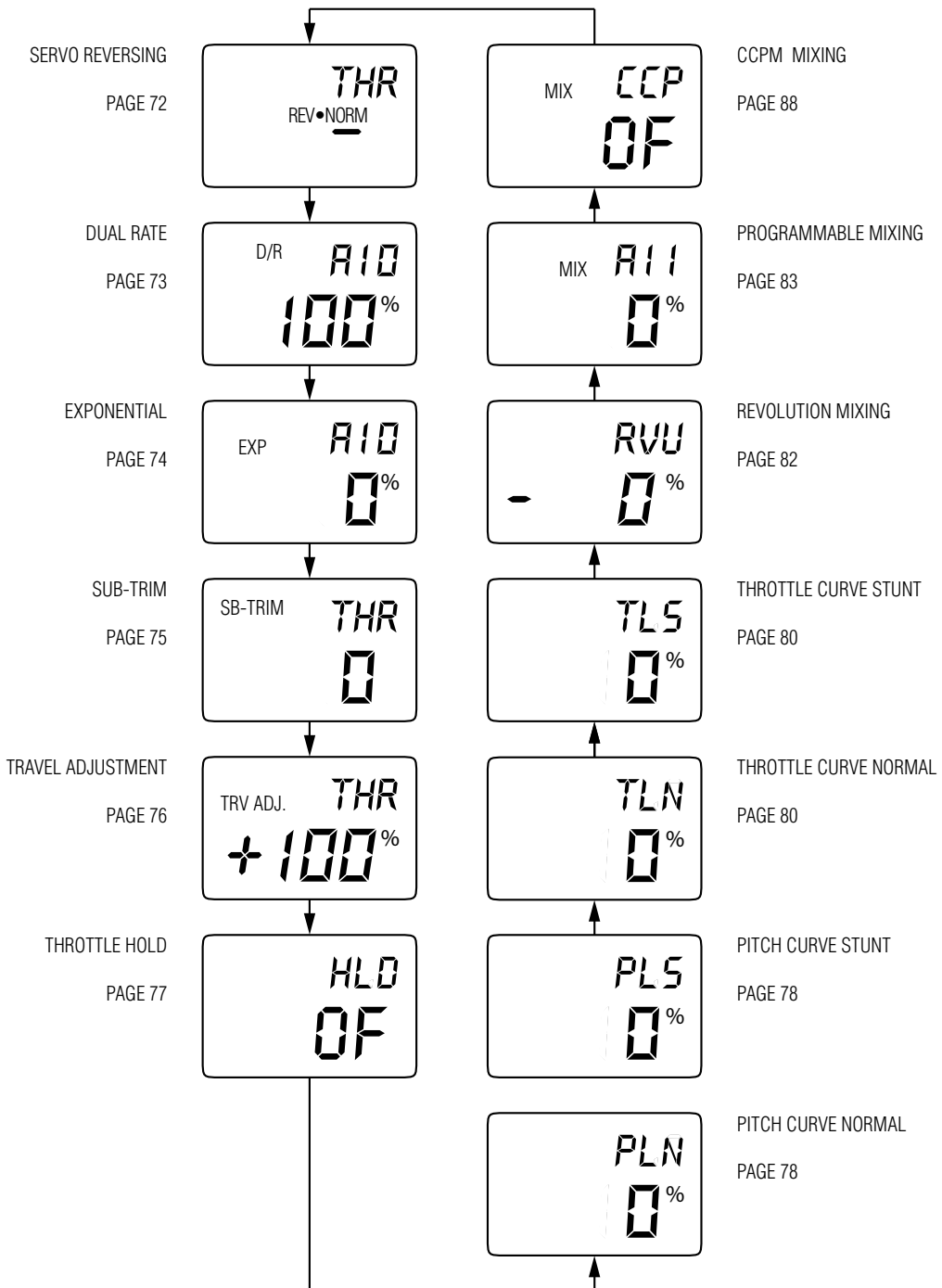

CHAPTER 6: FUNCTIONS (SYSTEM MODE)

MODEL TYPE SELECTION

Two types of aircraft programming are available with the DX6, airplane (AC) and helicopter (HE). When entering the model type selection function, the current model type will appear on the screen. (This will be the current model type set as the factory default or the last model used.) When you press the **INCREASE** or **DECREASE** button to change the model type, the new model type indicated on the screen will flash. For example, if the current model type is AC and you change to HE, "HE" will flash on the screen. The flashing alerts you to the change of model type and will stop once you move to the next function or exit the system mode.

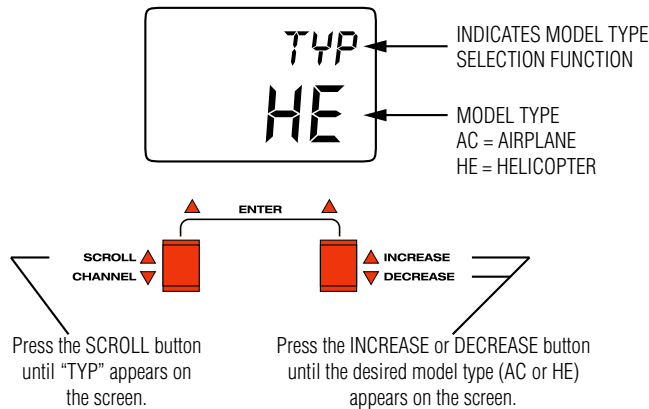

Note: When changing model type the programming will be reset to the factory default settings.

ACCESSING THE MODEL TYPE SELECTION FUNCTION

1. Press the **SCROLL** and **INCREASE** buttons simultaneously and hold.
2. Turn on the transmitter to enter the system mode.
3. Press the **SCROLL** button until "TYP" appears on the screen.
4. Press the **INCREASE** or **DECREASE** button until the desired model type appears on the screen (AC = airplane HE = helicopter).
5. Press the **SCROLL** button to access the Data Reset function.
6. To exit, press the **SCROLL** and **INCREASE** buttons simultaneously.

DATA RESET

The data reset function allows you to reset all the programming in the current model selected (1–10) to the factory default settings. Before using the Data Reset function, it is important to enter the model selection function and select the desired model number (1–10) for which you want to reprogram to the factory settings. The model selection function is described on page 70.

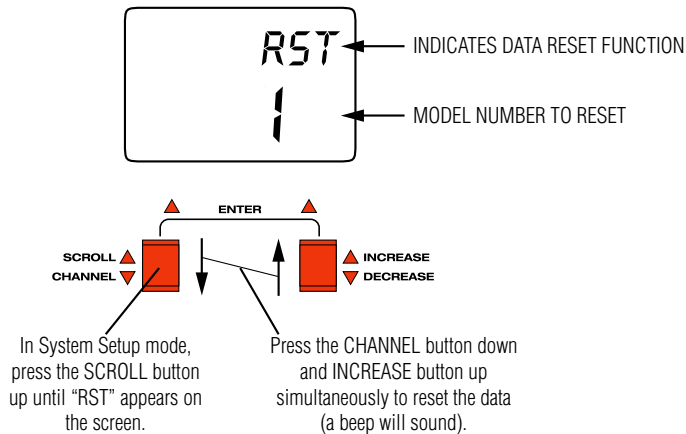

ACCESSING THE DATA RESET FUNCTION

1. Press the **SCROLL** and **INCREASE** buttons up simultaneously and hold.
2. Turn on the transmitter to enter the System mode.
3. Press the **SCROLL** button up until "RST" appears on the screen.
4. Press the **CHANNEL** and **INCREASE** buttons simultaneously to reset the data. (To confirm that the selected model's programming has been reset, a beep will sound and the model number will momentarily disappear from the screen.)
5. Press the **SCROLL** button to access the Model Select function.
6. To exit, press the **SCROLL** and **INCREASE** buttons up simultaneously.

DUAL RATE SWITCH SELECTION

The dual rate switch position is selectable and the elevator and aileron dual rates can be combined on one switch. This allows a single switch to be used when moving from high rates to low rates. Exponential Rate (EXP) is also available for both aileron and elevator and works in conjunction with the dual rate function to provide reduced sensitivity movements around neutral while allowing maximum servo travel. This reduces sensitivity in the middle portion of the stick control and still allows full travel at the end of the stick control. Refer to page 74 for exponential rate adjustment.

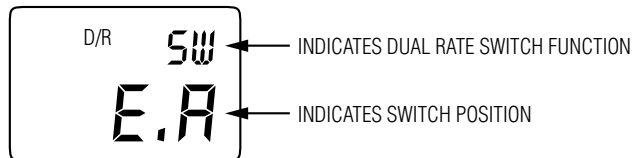

E.A = ELEVATOR AND AILERON OPERATE INDIVIDUALLY

A. = OPERATION OF ELEVATOR AND AILERON DUAL RATE ON AILERON DUAL RATE SWITCH

E. = OPERATION OF ELEVATOR AND AILERON DUAL RATE ON ELEVATOR DUAL RATE SWITCH

CF = COMBINED FUNCTION OPERATION OF ELEVATOR AND AILERON DUAL RATE ON THE FLIGHTMODE SWITCH

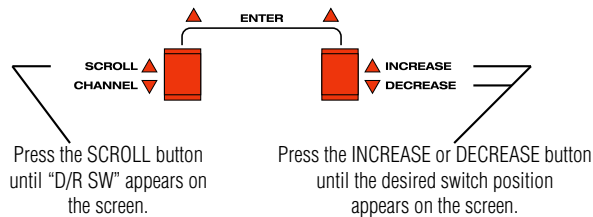

Note: For an easy method to add dual rate rudder see mixing page 87. Refer to page 74 for exponential rate adjustment.

ACCESSING THE DUAL RATE SWITCH SELECTION FUNCTION

1. Press the **SCROLL** and **INCREASE** buttons simultaneously and hold.
2. Turn on the transmitter to enter the system mode.
3. Press the **SCROLL** button until "D/R SW" appears on the screen.
4. Press the **INCREASE** or **DECREASE** button until the desired switch position appears on the screen. (E.A, A., E. or CF)
5. Press the **SCROLL** button to access the Wing Type selection function.
6. To exit, press the **SCROLL** and **INCREASE** buttons simultaneously.

GEAR/GYRO SWITCH SELECTION

The DX6 gear/gyro switch selection function enables the dual rate values of the gyro to be combined with one of four switches (flight mode, throttle hold, aileron dual rate, elevator dual rate). This feature is for use with gyros that offer a dual rate sensitivity adjustments.. The most common use for this feature would be to combine the gyro dual rate adjustment with the flight mode switch. This would then automatically alter the gyro sensitivity from normal (hover) to stunt (3D) when the flight mode switch is in use.

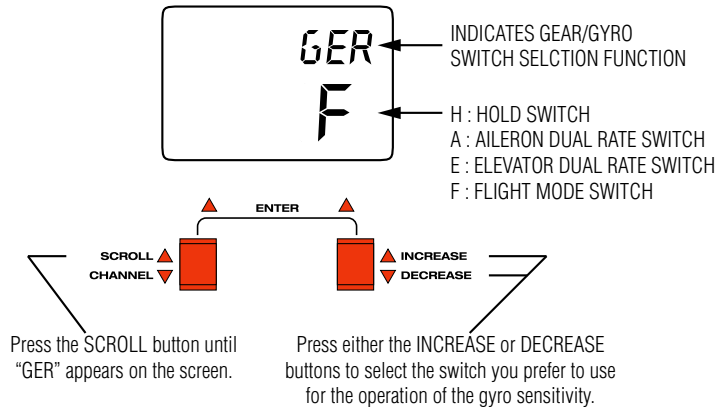

ACCESSING THE GEAR/GYRO SWITCH SELECTION FUNCTION

1. Press the **SCROLL** and **INCREASE** buttons simultaneously and hold.
2. Turn on the transmitter to enter the system mode.
3. Press the **SCROLL** button until "GER" appears on the screen.
4. Press the **INCREASE** or **DECREASE** button to select the switch you prefer to use for the operation of the gyro sensitivity.
5. Press the **SCROLL** button to access the Model Selection function.
6. To exit, press the **SCROLL** and **INCREASE** buttons simultaneously.

Note: The remote gain lead from the gyro should be plugged into channel 5 (gear) of the receiver. To adjust the Gyro gain use sub-trim (gear) and travel adjust (gear).

Press the **SCROLL** button until "GER" appears on the screen. Press either the **INCREASE** or **DECREASE** buttons to select the switch you prefer to use for the operation of the gyro sensitivity.

IMPORTANT GYRO INFORMATION

Note: After flight trimming the helicopter, or anytime the rudder trim is changed, It is important to rebind the system (see binding page 60) to set the fail-safe position to the rudders true neutral. With many types of gyros, each time the radio is turned on the gyro senses the servo output position and establishes this as the center for that flight.

When the DX6 receiver is first turned on, the servos are driven to their fail-safe positions until the receiver connects to the DX6 transmitter. This can take several seconds. If the fail-safe position for rudder is different than the rudder trim position, it is possible that the gyro will establish the fail-safe position as neutral instead of the trimmed neutral position. Making the rudder trim position and the fail-safe position the same prevents this from happening. In summary, after the helicopter is trimmed rebind the system to prevent the tail from drifting.

MODEL SELECTION

The DX6 has memory for ten models. It can store the settings for ten airplanes, ten helicopters, or any combination of both types of models.

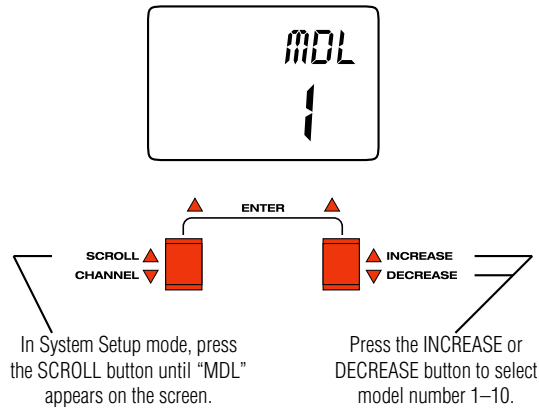

ACCESSING THE MODEL SELECTION FUNCTION

1. Press the **SCROLL** and **INCREASE** buttons upward simultaneously and hold.
2. Turn on the transmitter to enter the system mode.
3. Press the **SCROLL** button until "MDL" appears on the screen.
4. Press the **INCREASE** or **DECREASE** button to select model number 1 through 10.
5. Press the **SCROLL** button to access the Model Name entry function.
6. To exit, press the **SCROLL** and **INCREASE** buttons simultaneously.

MODEL NAME ENTRY

The DX6 allows a three-digit name to be input for each of the ten models available. The current model will be displayed in the normal display. This feature helps identify different aircraft types or model setups.

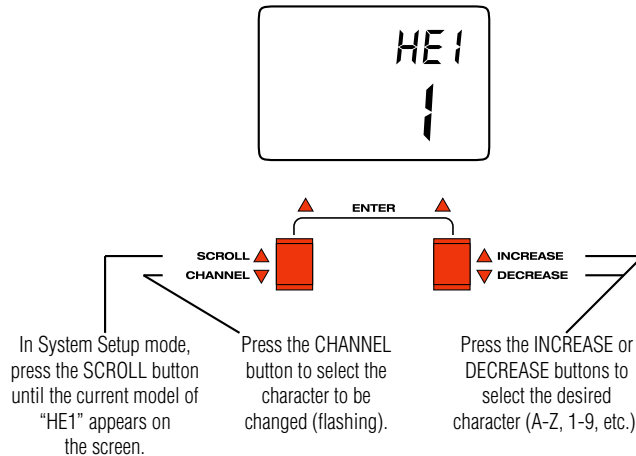

ACCESSING THE MODEL NAME ENTRY FUNCTION

1. Press the **SCROLL** and **INCREASE** buttons simultaneously and hold.
2. Turn on the transmitter to enter the System mode.
3. Press the **SCROLL** button until the current model or "HE1" appears on the screen.
4. Press the **INCREASE** or **DECREASE** buttons to select the correct letter/number for the first character (flashing).
5. To adjust the remaining two characters, press the **CHANNEL** button until the desired character to be adjusted is flashing.
6. Press the **SCROLL** button to access the Modulation Select function.
7. To exit, press the **SCROLL** and **INCREASE** buttons simultaneously.

CHAPTER 7: Function Mode

SERVO REVERSING

Servo reversing is a convenient function used in the setup of a new aircraft. It is used to change the direction of servo rotation in relation to the corresponding stick movement. Servo reversing is available for all six channels.

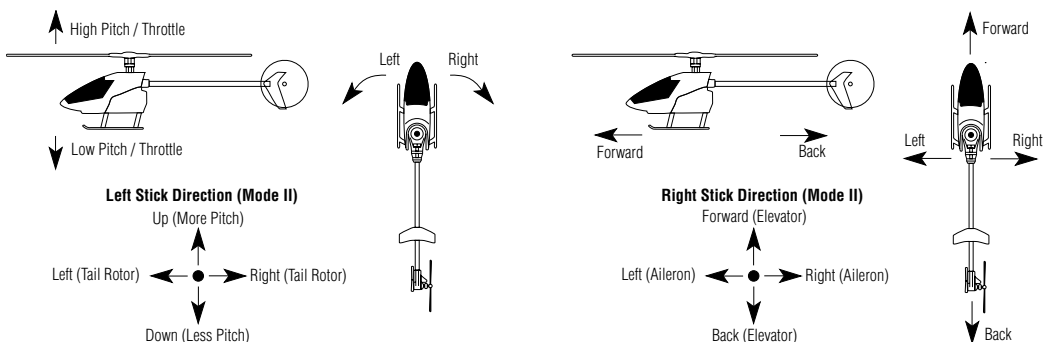
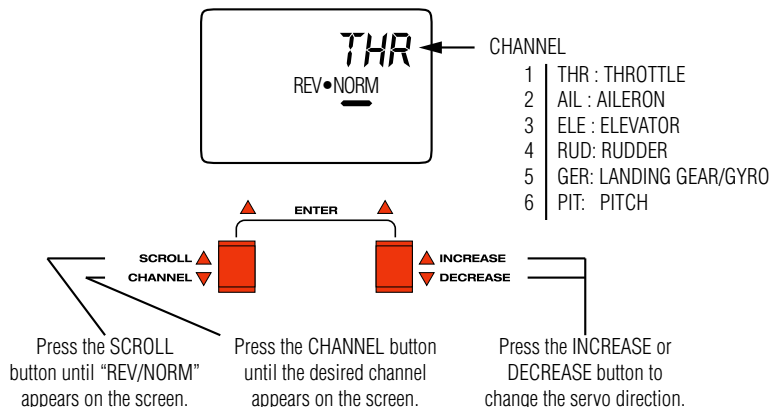

ACCESSING THE SERVO REVERSING FUNCTION

1. Turn on the transmitter.
2. Press the **SCROLL** and **INCREASE** buttons simultaneously to enter the function mode.
3. Press the **SCROLL** button until "REV-NORM" appears on the screen.
4. Press the **CHANNEL** button until the desired channel appears on the screen.
5. Press the **INCREASE** or **DECREASE** button to change the servo direction.
6. Press the **SCROLL** button to access the Dual Rate function.
7. To exit, press the **SCROLL** and **CHANNEL** buttons simultaneously.

DUAL RATE

Dual rate is available for the aileron and elevator channels. The purpose of this function is to allow for in-flight selection of two preset servo travels for each of these channels. The amount of travel is adjustable from 0-125%. The factory settings for both switch positions (0 and 1) are 100%. Either position may be selected as the low or high rate by placing the switches in the desired position and adjusting the value for that position. Operation of these switches is described on page 68.

Note: For an easy way to add dual rate rudder see Programming a Rudder Dual Rate on page 87.

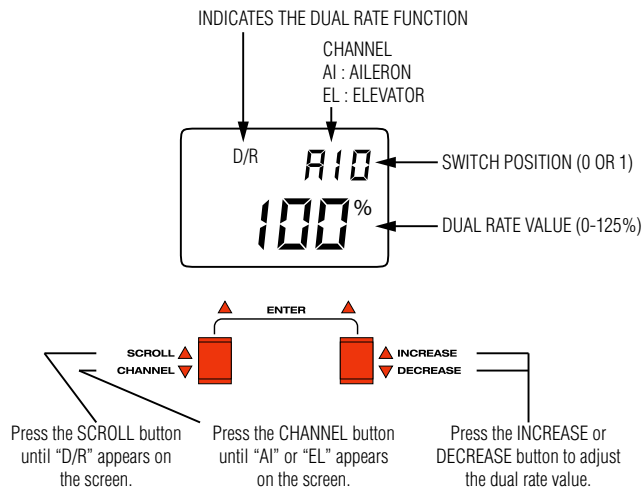

ACCESSING THE DUAL RATE FUNCTION

1. Turn on the transmitter.
2. Press the **SCROLL** and **INCREASE** buttons simultaneously to enter the function mode.
3. Press the **SCROLL** button until "D/R" appears on the screen.
4. Press the **CHANNEL** button until the desired channel appears on the screen (AI = aileron or EL = elevator).
5. The number that appears directly to the right of the selected channel is the switch position. There are two switch positions, 0 and 1, for each of the channels. A "0" will appear when the selected dual rate switch is in the uppermost position and a "1" when the selected switch is in the lower position.
6. To change the switch selection you must enter the dual rate switch selection function in the system mode (see page 68).
7. The number in the center of the screen indicates the current dual rate value for the selected switch position and channel. Press the **INCREASE** or **DECREASE** button to adjust the dual rate value (0–125%).
8. After adjusting the value for the 0-switch position, change to the 1-switch position and adjust the rates.
9. Press the **CHANNEL** button to select the other channel and adjust the dual rate value for both switch positions.
10. Press the **SCROLL** button to access the Exponential Rate feature.
11. To exit, press the **SCROLL** and **INCREASE** buttons simultaneously.

EXPONENTIAL

Programmable exponential adjustments are offered on the aileron and elevator channels on the DX6 system. Exponential is a function that allows you to tailor the response rate of the controls as compared to the stick inputs. The purpose of exponential is to reduce the sensitivity in the middle portion of stick movement, while still allowing full travel at the end of the stick movement. The adjustable range of the Exponential function is from 0–100%. Zero percent (0%) is linear stick control which means that the response rate is equal throughout the stick control. One hundred percent (100%) is full exponential. The larger the exponential value, the less servo action, or sensitivity, you will notice around the neutral setting.

Note: The Exponential function operates in conjunction with the Dual Rate function. It is imperative to understand the Dual Rate function prior to adjusting the exponential values. Exponential may be selected independently for either the high or low rate (position 0 or 1) or both.

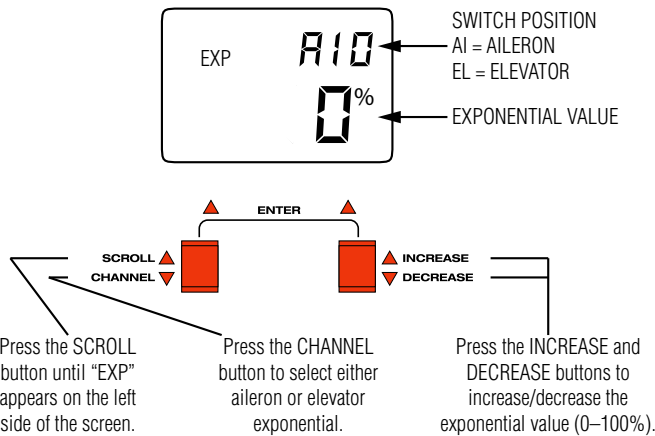

ACCESSING THE EXPONENTIAL FUNCTION

1. Turn on the transmitter.
2. Press the **SCROLL** and **INCREASE** buttons simultaneously to enter the Function mode.
3. Press the **SCROLL** button until "EXP" appears at the left side of the screen.
4. Press the **CHANNEL** button until the desired channel appears on the screen (AI or EL).
5. Using the appropriate dual rate switch, select the correct position to be adjusted (0 or 1).
6. Press the **INCREASE** or **DECREASE** buttons to increase or decrease the exponential value.
7. Press the **SCROLL** button to access the Sub-Trim function.
8. To exit, press the **SCROLL** and **INCREASE** buttons simultaneously.

SUB-TRIM

Sub-trim is an electronic trim that is available for each of the six channels. Sub-trim is particularly useful to precisely neutralize the servo position electronically, when it difficult to achieve the desired position mechanically.

Note: It is recommended to use minimal sub trim values as possible for adjustment. If more that 20–30 points are required, it is suggested that a mechanical linkage adjustment be performed at the servo by rotating the servo horn on the spline and adjusting the linkage.

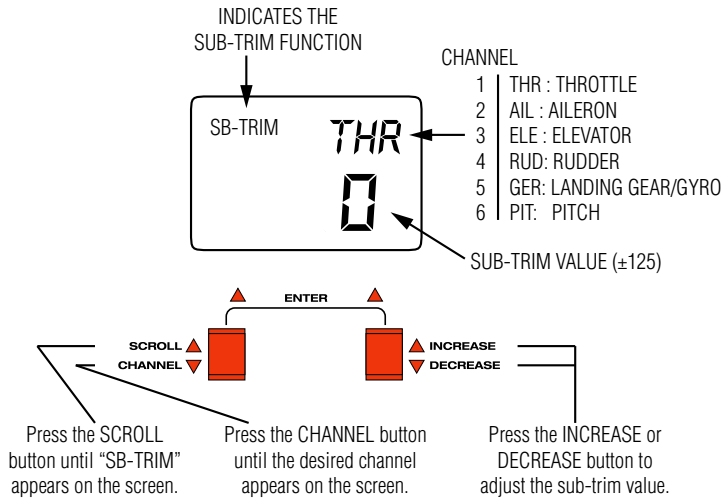

ACCESSING THE SUB-TRIM FUNCTION

1. Turn on the transmitter.
2. Press the **SCROLL** and **INCREASE** buttons simultaneously to enter the function mode.
3. Press the **SCROLL** button until "SB-TRIM" appears on the screen.
4. Press the **CHANNEL** button until the desired channel appears on the screen.
5. Press the **INCREASE** or **DECREASE** button to establish the desired amount of sub-trim.
6. Press the **SCROLL** button to access the travel adjustment function.
7. To exit, press the **SCROLL** and **INCREASE** buttons simultaneously.

TRAVEL ADJUSTMENT

The amount of servo travel is adjustable in each direction independently for each of the six channels. The adjustment range is from 0% to 150%. Travel adjustment is factory set at 100% for all channels. The travel adjustment value direction displayed on the screen coincides with the position of the stick or switch (e.g., flap switch, gear switch). This function is useful to adjust control surface travel without the need for mechanical adjustment.

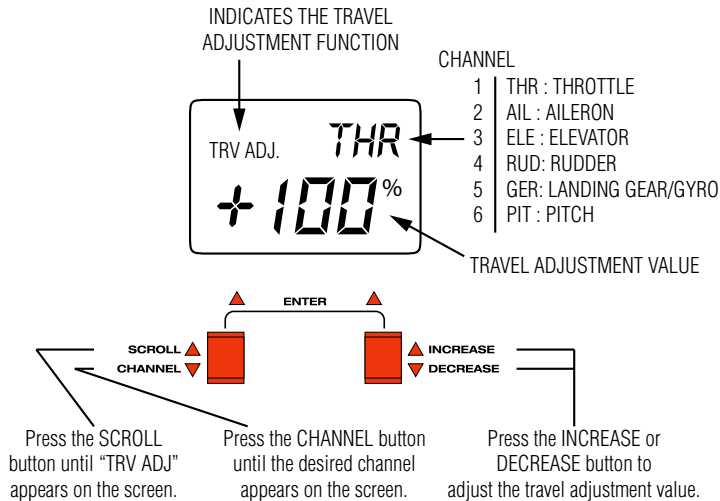

ACCESSING THE TRAVEL ADJUSTMENT FUNCTION

1. Turn on the transmitter.
2. Press the **SCROLL** and **INCREASE** buttons simultaneously to enter the function mode.
3. Press the **SCROLL** button until "TRV ADJ." appears on the screen.
4. Press the **CHANNEL** button until the desired channel appears on the screen.
5. Move the selected channel stick or switch in the direction that you want to adjust the travel. Press the **INCREASE** or **DECREASE** button to achieve the desired travel. Move the stick in the opposite direction to adjust the travel in the opposite direction.
6. The same may be done for all channels.
7. Press the **SCROLL** button to access the aileron- to-rudder mixing function.
8. To exit, press the **SCROLL** and **INCREASE** buttons simultaneously.

THROTTLE HOLD

The throttle hold function enables the throttle to be held in a specific location, while allowing the remaining channels to function normally. The purpose of this function is for autorotation landings, however, many pilots find throttle hold useful as an arming switch for electric helicopters to prevent the motor from accidentally running if the sticks or switches are bumped, or in the wrong position. When the throttle hold function is activated, a third adjustable pitch curve is available in the pitch curve screen. The throttle hold switch is located on the top right rear corner of the transmitter. Throttle hold is on when the switch is in the forward position.

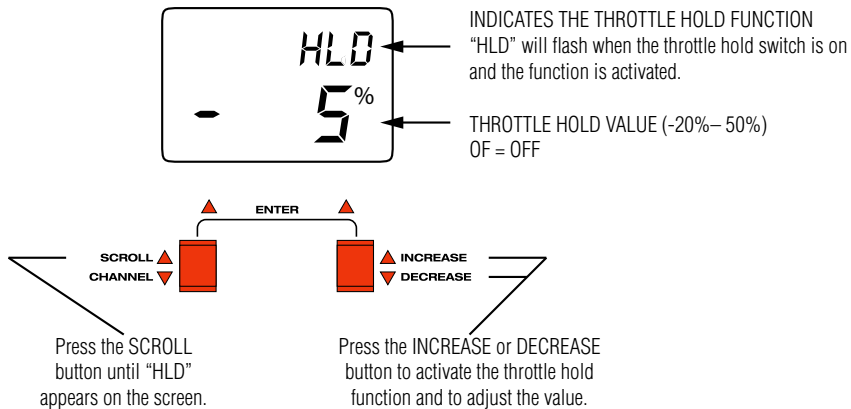

ACCESSING THE THROTTLE HOLD FUNCTION

1. Turn on the transmitter.
2. Press the **SCROLL** and **INCREASE** buttons simultaneously to enter the Function mode.
3. Press the **SCROLL** button until "HLD" appears on the screen.
4. The factory setting for the Throttle Hold function is off.

Note: When the Throttle Hold function is off, the throttle hold pitch curve will not appear in the pitch curve function. Press the **INCREASE** or **DECREASE** button to activate the Throttle Hold function. The throttle hold pitch curve will now appear in the pitch curve function. To inhibit the Throttle Hold function, press the **CHANNEL** and **INCREASE** buttons simultaneously.

5. Using the **INCREASE** or **DECREASE** button, adjust the throttle hold value to the desired position, the normal range of throttle hold is from -2 (1/2 trim) to +15 (full high trim).
6. Press the **SCROLL** button to access the pitch curve function.
7. To exit, press the **SCROLL** and **INCREASE** buttons simultaneously.

PITCH CURVE

The DX6 offers three independent pitch curves with three adjustable points per curve. This function allocates a separate pitch curve setting during Normal, Stunt, and Throttle Hold modes to maximize flight performance. Once the pitch curves are established, each can be activated in flight using the two-position flight mode switch and the throttle hold switch. Each of the three points on the pitch curve is independently adjustable from 0–100%. These three points correspond to the low, middle, and high positions of the throttle stick (collective). The factory preset values for all three pitch curves are: Low 0%, Middle 50%, and High 100%.

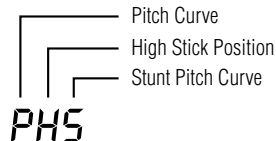
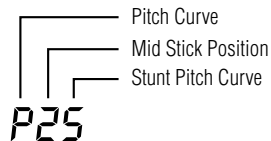
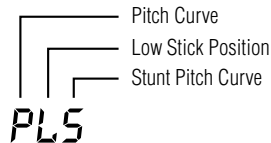
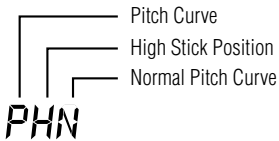
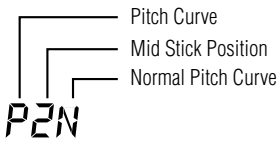
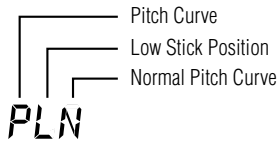
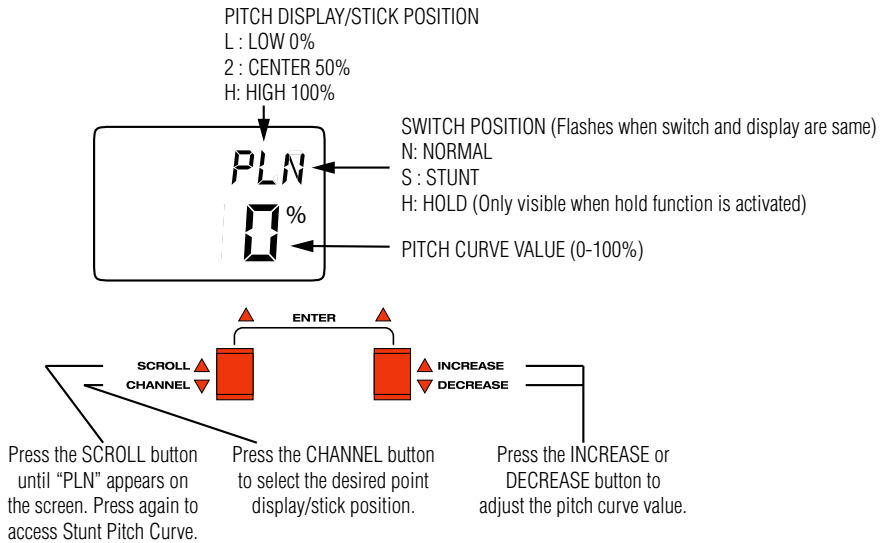

ACCESSING THE PITCH CURVE FUNCTION

1. Turn on the transmitter.
2. Press the **SCROLL** and **INCREASE** buttons simultaneously to enter the Function mode.
3. Press the **SCROLL** button until "PLN" appears on the screen. The letter to the far right indicates the specific pitch curve section that you are in (N, S or H). The letter in the center indicates the point that is selected.
4. Press the **CHANNEL** button to select the pitch point of the pitch curve you want to change.
5. Press the **INCREASE** or **DECREASE** button to change the value of the current reference point. The range of each point is adjustable from 0–100% in 1% intervals.
6. To set the pitch curve for the stunt (flight) mode, press the **SCROLL** button once to access PLS. Repeat Step 5 and Step 6 to adjust.
7. To set the pitch curve for the throttle hold mode, press the **SCROLL** button once to access PLH. Repeat Step 5 and Step 6 to adjust.
8. Press the **SCROLL** button to access the throttle curve function.

Note: If throttle hold is not activated, the Throttle Curve function will be accessed.

9. To exit, press the **MODE** and **CHANNEL** buttons simultaneously.

THROTTLE CURVE

Adjustment of the throttle curve is very similar to the pitch curve adjustment described in the preceding section. Two throttle curves are available—normal and stunt. The normal or hover throttle curve has three points (L, 2, H) and the stunt or flight throttle curve has two points (L and 2). The two throttle curves are activated by the flight mode switch located on the top left rear corner of the transmitter. The throttle curve is in the normal mode when the flight mode switch is in the back position. The throttle curve is in the stunt mode when the flight mode switch is in the forward position.

Note: In Stunt mode (S), the high position of the throttle curve is preset to 100%, and is not adjustable.

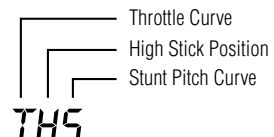
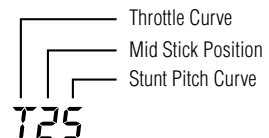
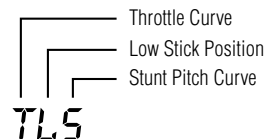
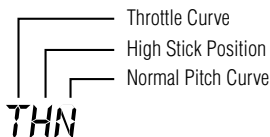
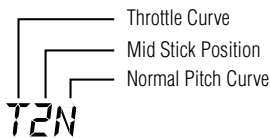
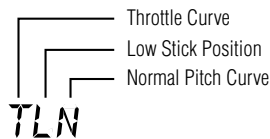
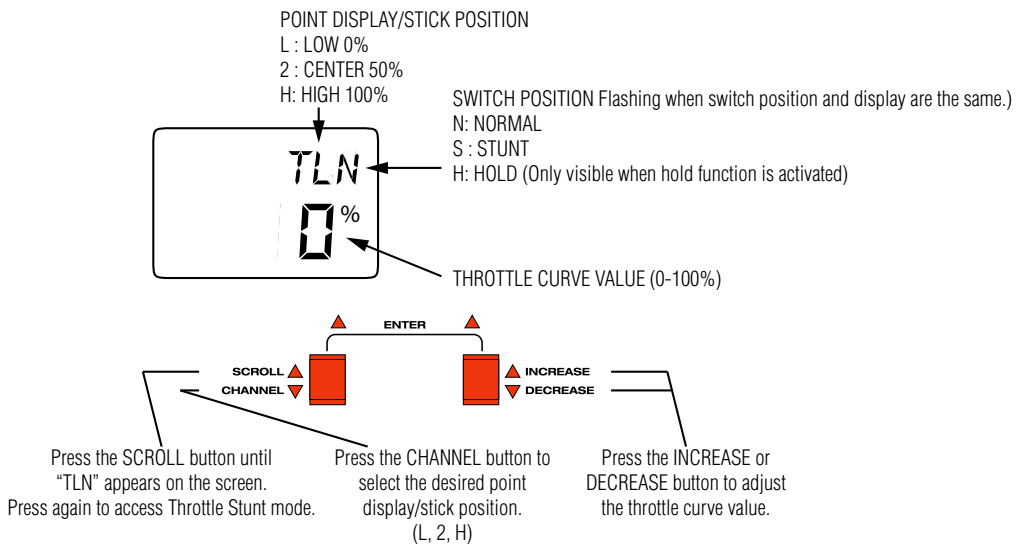

ACCESSING THE THROTTLE CURVE FUNCTION

1. Turn on the transmitter.
2. Press the **SCROLL** and **INCREASE** buttons simultaneously to enter the function mode.
3. Press the **SCROLL** button until "TLN" appears on the screen. The letter to the far right indicates the specific throttle curve mode that you are in (N, S, or H). The letter in the center indicates the throttle point that you can adjust.
4. Press the **CHANNEL** button to select the throttle point of the throttle position that you have selected (L, 2, or H).
5. Press the **INCREASE** or **DECREASE** button to change the value of the current reference point. The range of each point is 0–100% in 1% intervals.
6. To set the throttle curve for the stunt (flight) mode, press the **SCROLL** button once. Then, repeat Steps 5 and 6 to adjust.
7. Press the **SCROLL** button once to access the Revolution Mixing function.
8. To exit, press the **SCROLL** and **INCREASE** buttons simultaneously.

REVOLUTION MIXING

Revolution Mixing is only used with conventional (non-heading hold) gyros. The Revolution Mixing function combines tail rotor input with the throttle/collective function to counteract the torque created by the engine. When properly adjusted, the helicopter will climb and descend without a tendency to yaw in either direction. Revolution mixing is for use with non-heading lock gyros only. Since the torque created by the main rotor blades varies with different throttle/pitch settings, it is necessary for the tail rotor blades to change pitch in unison. The “U” or up mixing adjusts the tail rotor compensation from the mid to high throttle stick setting. The “D” or down mixing adjusts the tail rotor compensation from the mid to the low throttle stick setting.

REVOLUTION MIXING SET-UP PROCEDURE

1. Set up the helicopter so that it will maintain a stable hover with the tail rotor trim in the center position. Next, bring the helicopter into a steady vertical climb. The body of the helicopter will move in the opposite direction to the main rotor rotation. Increase the “U” or up mixing until the helicopter climbs without the tendency to rotate.
2. At a safe altitude, reduce the throttle. The helicopter will descend, and the body will turn in the same direction as the main rotor blades. Increase the “D” or down mixing until the helicopter descends without the tendency to rotate.

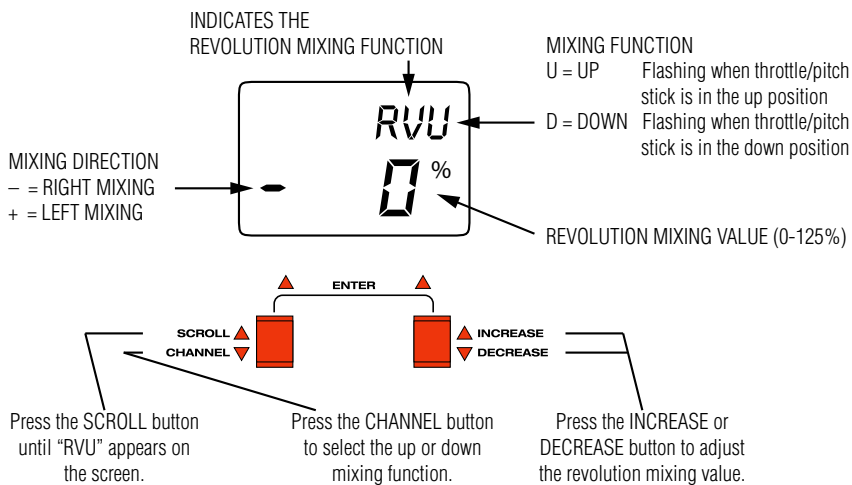

ACCESSING THE REVOLUTION MIXING FUNCTION

1. Turn on the transmitter.
2. Press the **SCROLL** and **INCREASE** buttons simultaneously to enter the Function mode.
3. Press the **SCROLL** button until “RVU” appears on the screen.
4. Press the **CHANNEL** button to select the up or down Mixing function.
5. Press the **INCREASE** or **DECREASE** button to adjust the mixing value of the applicable function. Press the **CHANNEL** and **INCREASE** buttons simultaneously to reset the mixing value to 0%. To change the mixing direction, press the **CHANNEL** and **INCREASE** buttons simultaneously again.
6. Press the **SCROLL** button to access the Programmable Mix A function.
7. To exit, press the **SCROLL** and **INCREASE** buttons simultaneously.

PROGRAMMABLE MIXING (A)

The DX6 in Helicopter mode offers one (1) programmable mix to be used for a number of different purposes. The functions allow mixing any one channel to any other channel. The mix can remain on at all times or be switched off in flight using a number of different switches. Each channel is identified by channel numbers 1-6 (i.e., 2 = aileron, 4 = rudder, etc). The channel appearing first is known as the Master channel or the channel to which you want to mix. The second channel is known as the Slave channel or the channel that is being mixed into the Master channel. For example, 3-2 would indicate would indicate elevator-to-aileron mixing each time the elevator stick is moved, the elevator will deflect, and the aileron will automatically move in the direction and to the value input. Mixing is proportional, so small inputs of the master channel will produce small outputs of the slave channel. Each programmable mix has a mixing "offset." The purpose of the mixing offset is to redefine the neutral position of the slave channel. The elevator-aileron mix mentioned above is most commonly used to trim the helicopter for proper loop tracking.

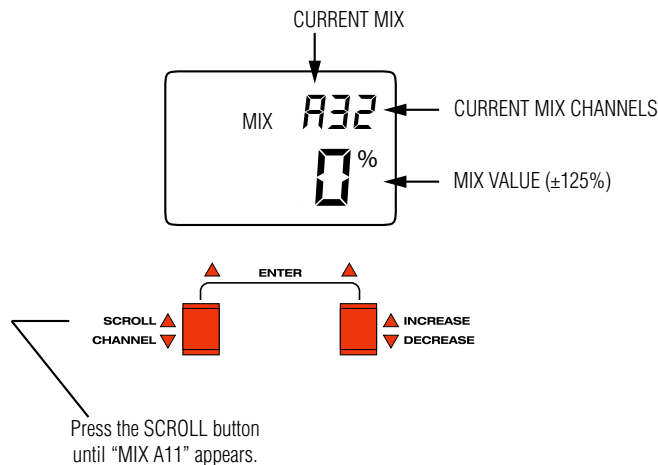

ACCESSING THE PROGRAMMABLE MIXING FUNCTION

1. Turn on the transmitter
2. Press the **SCROLL** and **INCREASE** buttons simultaneously to enter the Function mode.
3. Press the **SCROLL** button until "MIX A32" appears at the top right corner of the screen.
This is program mix A.

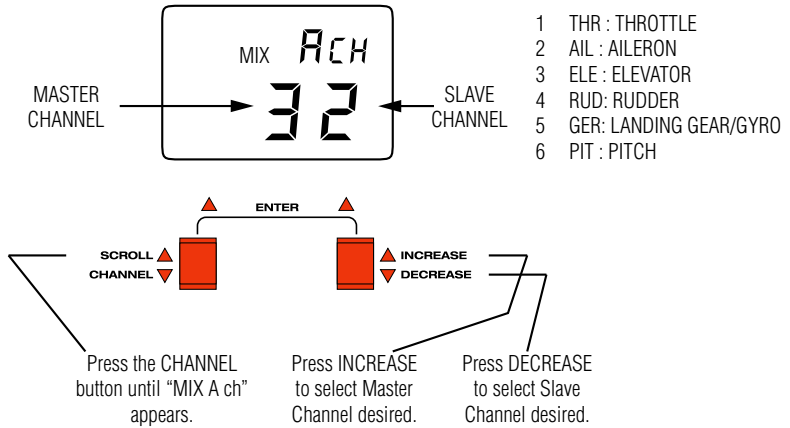

ASSIGNING CHANNELS

1. Press the **CHANNEL** button twice until "MIX A CH" appears on the screen.
2. Press the **INCREASE** button to select the desired "Master channel" (1-6).
3. Press the **DECREASE** button to select the desired "Slave channel" (1-6).

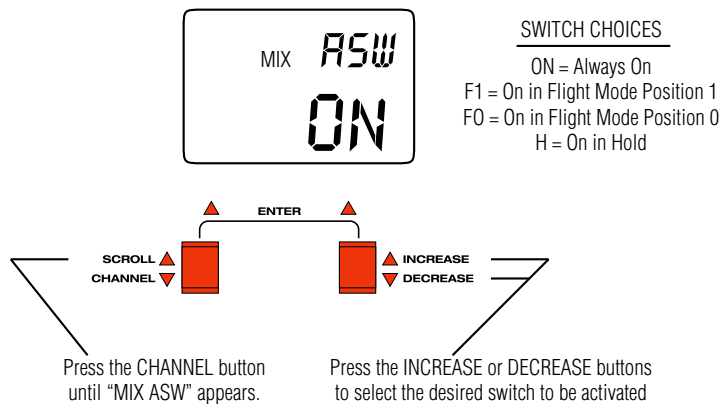

SWITCH SELECTION

1. Press the **CHANNEL** button once until "MIX ASW" appears.
2. Press the **INCREASE** or **DECREASE** button to select the desired switch to be used to activate the mixing, or leave on if a constant mix is desired.

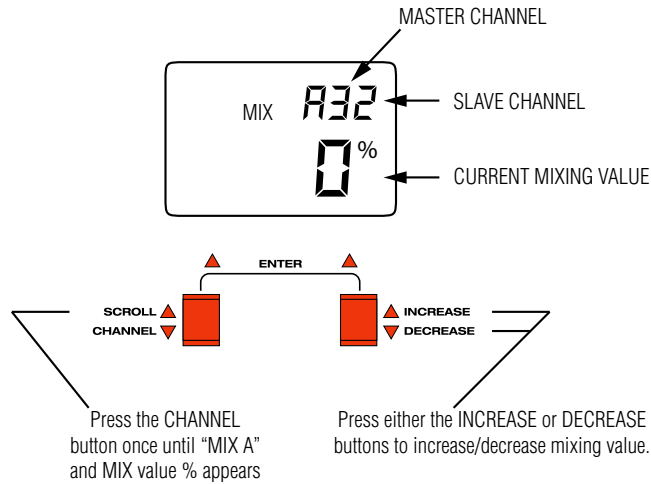

MIXING VALUE ADJUSTMENT

1. Press the **CHANNEL** button once until "Mix A" appears, with the mixing value located at the bottom of the screen.
2. To set the slave channels mixing value, move and hold the master channel control stick to the direction to be adjusted (up/down—left/right), then press the **INCREASE** key to add positive mixing value or the **DECREASE** key to add negative mixing value (+/-125%). When the master channels stick is moved, the display will automatically show the mixing value for the current stick direction.

Note: If a mix switch position other than "ON" is selected, it will be necessary to move the selected switch to the on, or active, position to adjust the mixing value. "OF" will appear on the screen if the selected mixing switch is in the off position.

OFFSET

MIXING OFFSET ADJUSTMENT

The purpose of the mixing offset feature is to redefine the neutral position of the slave channel to be mixed. Any desired position may be selected for the offset reference point. To set the offset position, Place the master channel's stick to the desired position and press either the **INCREASE** or **DECREASE** keys.

This position is now stored in the memory and its offset value from the neutral position of the master channel is indicated numerically on the LCD display.

Then, the mixing value at the determined offset position is now set at 0.

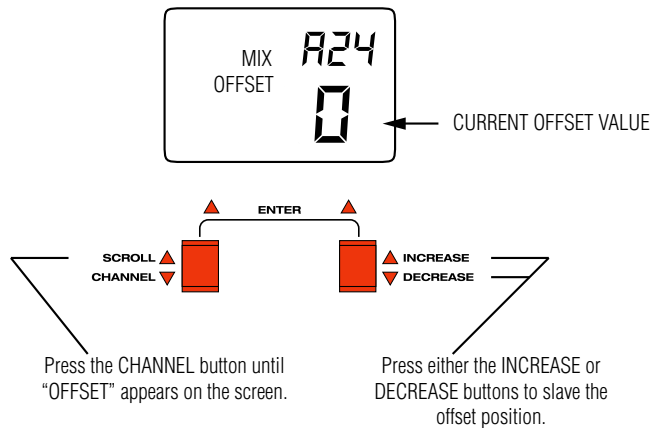

ACCESSING THE OFFSET FUNCTION

1. Press the **CHANNEL** button once until Mix Offset appears in the center of the screen.
2. Place the master channel stick to the desired offset position, then press either the **INCREASE** or **DECREASE** button to store the offset. The offset value will be displayed.
3. Press the **SCROLL** button once to access Program Mix B, press twice to access program MIX C, and a third time for servo reversing.
4. To exit the Function mode, press the **SCROLL** and **INCREASE** buttons simultaneously.

Note: If a mix switch position other than on has been selected, it will be necessary to move the selected switch to the on or active position to set the offset value. "OF" will appear on the screen if the selected mixing switch is in the off position.

PROGRAMMING A RUDDER DUAL RATE

Programmable mixing is a powerful feature that offers many creative options. As an example a dual rate rudder can be easily added and turned on/off via a selected switch. By mixing rudder to rudder, (4-4) selecting the desired switch to turn on/off the mix and by assigning positive values to increase the rudder travel, or negative values to reduce the travel, a rudder dual rate is added that offers independent throw values in each direction. Following are the steps to add a rudder dual rate:

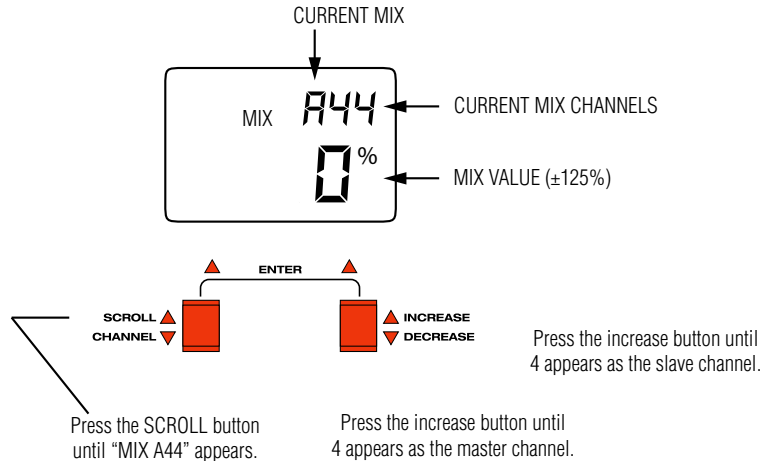

PROGRAMMING A RUDDER DUAL RATE

1. Turn on the transmitter.
2. Press the **SCROLL** and **INCREASE** buttons simultaneously to enter function mode.
3. Press the **SCROLL** button until mix A11 appears at the top right corner of the screen.
4. Press the **INCREASE** button until 4 (rudder) appears on the screen as the master channel.
5. Press the **DECREASE** button until 4 (rudder) appears on the screen as the slave channel.
6. Move the rudder stick in the desired direction and press the **INCREASE** or **DECREASE** button to set the desired rudder dual rate travel.

Note: A positive value will increase the rudder travel, while a negative value will decrease the rudder travel.

7. Move the rudder stick in the opposite direction to adjust that direction's value.

CCPM SWASHPLATE MIXING

CCPM (Cyclic Collective Pitch Mixing) mixing is used for helicopters that utilize a 120° CCPM swashplate control system. CCPM is a type of mixing where three servos are connected to the swashplate and operate in unison and independently to control pitch and cyclic inputs. Refer to the diagram below for proper 120° Three Servo-CCPM identification and connection.

THREE-SERVO (120 DEGREES) CCPM MIXING

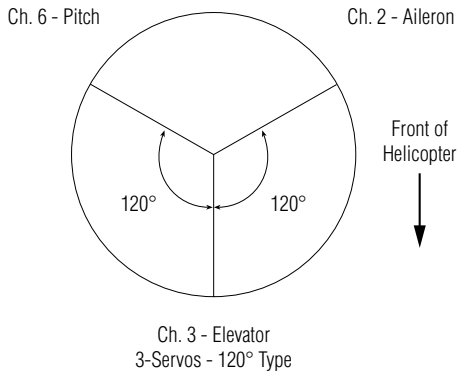

Please refer to the helicopter manufacturer's instructions for proper mixing values. Please also note that if control system interaction exists (pitch to aileron, pitch to elevator movement, etc.), it will be necessary to alter the travel adjust values for channels 2, 3, and 6 to correct this situation.

Note: The CCPM Swashplate Mixing function is designed for use only with helicopters that incorporate the 120° three-servo CCPM control system.

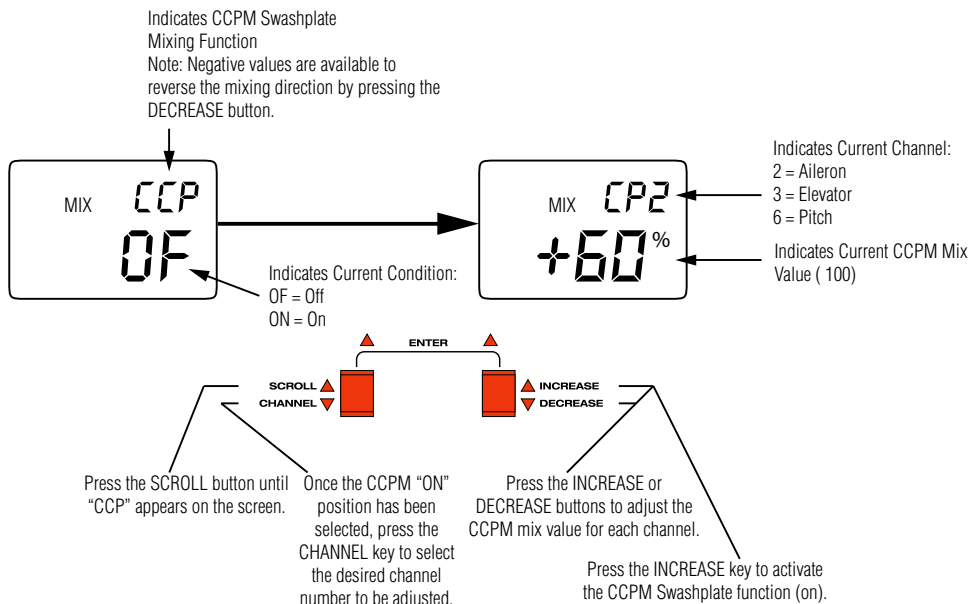

ACCESSING THE CCPM SWASHPLATE MIXING FUNCTION

1. Turn on the transmitter.
2. Press the **SCROLL** and **INCREASE** buttons simultaneously to enter the function mode.
3. Press the **SCROLL** button until "CCP" appears on the screen.
4. Press the **INCREASE** button once to activate the CCPM Swashplate Mix function. The screen will then move to the "CP2" screen, indicating that the CCPM function is now on.
5. Press the **CHANNEL** button to select the desired channel number to be adjusted.
6. Press the **INCREASE** or **DECREASE** buttons to select the desired mixing value for each channel (+100).
7. Press the **SCROLL** button once to access the servo reversing function.
8. To exit, press the **SCROLL** and **INCREASE** buttons simultaneously.

CCPM SERVO LOCATIONS

The 120° CCPM system requires the use of three servos to operate, Aileron, Elevator, and AUX 1 (Pitch). The labeling of these servos can become quite confusing because with the CCPM function, the three servos no longer work independently, but rather as a team, and their functions are now combined. For this reason, we will refer to the three servos in the following manner:

Aileron Servo: We will refer to this servo as the “Left” servo. The channel number for this servo is CH2.

Elevator Servo: We will refer to this servo as the “Front or Rear” servo. The channel number for this servo is CH3.

AUX 1 (Pitch) Servo: We will refer to this servo as the “Right” servo. The channel number for this servo is CH6.
Please refer to the CCPM connections chart below for clarification.

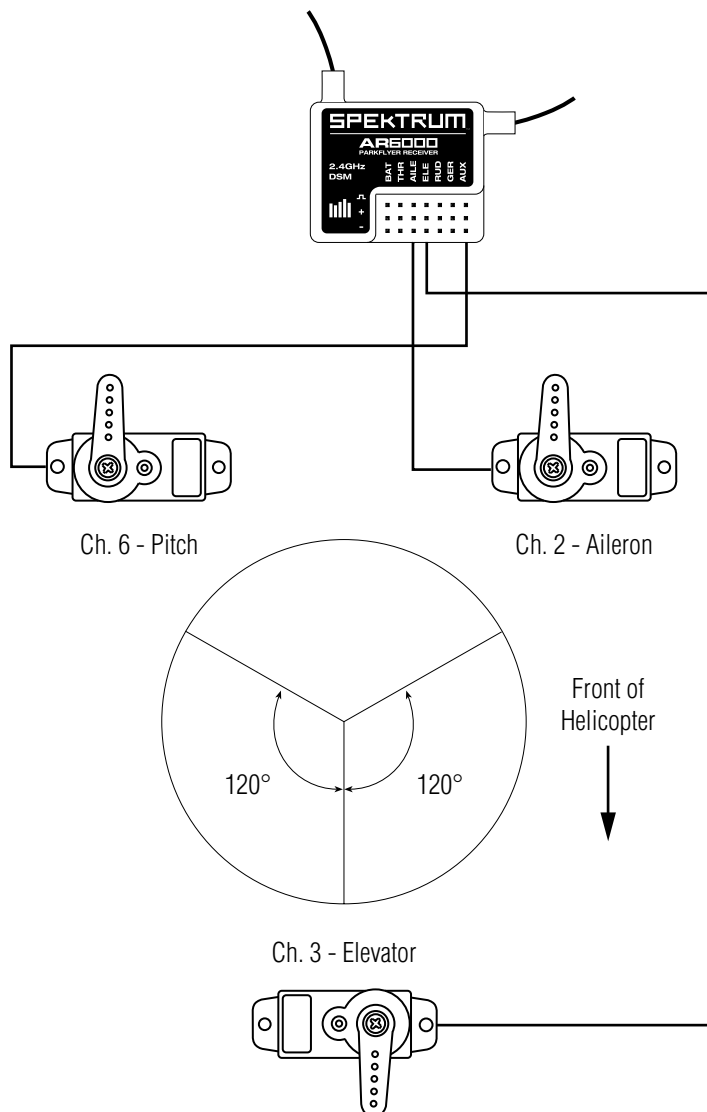

CCPM SERVO CONNECTIONS

HOW 120 CCPM WORKS

120° Three-Servo CCPM relies on the radio's special programming rather than a mechanical mixer to operate the swashplate to achieve pitch and cyclic control. The radio's 120° Three-Servo CCPM function automatically mixes the three servos to provide the correct mixing inputs for aileron (roll), elevator (fore and aft pitch), and collective pitch. The following is an example of how each control input affects the servo's movement:

1. COLLECTIVE

When a collective pitch input is given, all three servos move simultaneously in the same direction, at equal amounts, to raise and lower the swashplate while keeping the swashplate level. During this function, all three servos travel in the same direction at the same value so that the swashplate can remain level during the increase and decrease in pitch. This mixing of the three servos is achieved through the transmitter's programming.

2. ELEVATOR (PITCH)

When an elevator input is given, all three servos must move to tilt the swashplate fore and aft. Two servos (aileron and pitch) move the swashplate in the same direction, while the elevator servo moves in the opposite direction such that the swashplate will tilt fore or aft. During this function, the elevator servo travels at 100%, while the other two servos travel at 50% (1/2 the travel value). This difference in travel is necessary due to the fact that the position of the front control ball is two times the distance of the two rear control ball positions, as measured from the center of the swashplate.

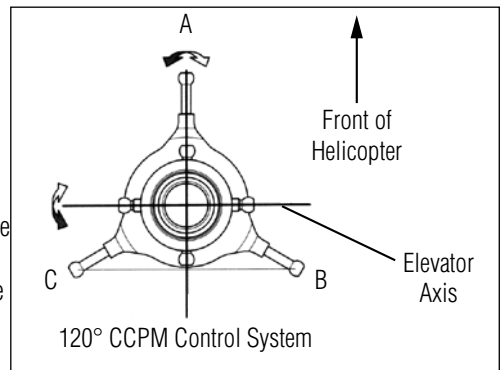

3. AILERON (ROLL)

When an aileron (roll) input is given, the aileron and pitch servos travel in opposite directions, while the elevator servo remains motionless, tilting the swashplate right or left. The travel value for each of the two rear servos is 100%.

IMPORTANT GYRO INFORMATION

Note: After flight trimming the helicopter, or anytime the rudder trim is changed, it is important to rebind the system (see Binding page 60) to set the fail-safe position to the rudder's true neutral. With many types of gyros, each time the radio is turned on, the gyro senses the servo output position and establishes this as the center for that flight.

When the DX6 receiver is first turned on, the servos are driven to their fail-safe positions until the receiver connects to the DX6 transmitter. This can take several seconds. If the fail-safe position for rudder is different than the rudder trim position, it is possible that the gyro will establish the fail-safe position as neutral instead of the trimmed neutral position. Making the rudder trim position and the fail-safe position the same prevents this from happening. In summary, after the helicopter is trimmed, rebind the system to prevent the tail from drifting.

CHAPTER 8: Data Sheet

MODEL NUMBER _____

MODEL NAME _____

CHANNELS	THRO (1)	AIL (2)	ELE (3)	RUDD (4)	GER (5)	AUX1 (6)
REVERSE SW	NORM • REV	NORM • REV	NORM • REV	NORM • REV	NORM • REV	NORM • REV
SUB-TRIM						
TRAVEL ADJUST (TRV ADJ)	+ %	+ %	+ %	+ %	+ %	+ %
	- %	- %	- %	- %	- %	- %
%						

D/R SW	EA • A • E • CF
--------	-----------------

GEAR SW	F • H • A • E
---------	---------------

THRO HOLD (HLD)	ON • OFF	POSITION
		±

REVO MIX (RV)	+	UP (U)	%
	-	DOWN (D)	%

CCPM MIXING		ON • OFF	
AIL (2)	ELE (3)	PITCH (6)	
+ %	+ %	+ %	
- %	- %	- %	

DUAL RATE • EXP			AILE (AI)	ELEV (EL)
	POS 0	D/R	%	%
		EXP	%	%
	POS 1	D/R	%	%
EXP		%	%	

		L	2	H
THRO CURVE TLN, T2N, THN	N	%	%	%
TLS, T2S	S	%	%	%
PITCH CURVE PLN, P2N, PHN	N			
PLS, P2S, PHS	S			
PLH, P2H, PHH	H			

PROG. MIX		CHANNEL MASTER ⇔ SLAVE	MIX SWITCH	OFFSET	+GAIN	-GAIN
	A	⇔	ON • F1 • F0 • H			

One Year Warranty

This Spektrum™ product is guaranteed against workmanship and manufacturing defects for a period of 1 year from the original date of purchase. This warranty is limited to the original purchaser and cannot be transferred. Warranty repair will cover all units except those that have been modified, misused, improperly installed, or serviced by an unauthorized service center. As with all fine electronics, avoid exposing your equipment to extreme temperatures, humidity, moisture, or exposure to direct sunlight for long periods of time.

Horizon Hobby, Inc. reserves the right to inspect any and all equipment involved in a warranty claim. Repair or replacement decisions are determined exclusively by Horizon Hobby, Inc. This warranty does NOT cover consequential, incidental or collateral damage under any circumstances. In no case shall Horizon Hobby's liability exceed the original cost of the purchased kit. Due to the nature of this product and its use, by the act of using the product the user accepts all resulting liability.

If you have any questions about the operation or installation of this product, please feel free to call a product support representative at 1-877-504-0233.

If your equipment needs to be repaired, ship it to:

Horizon Service Center
ATTN: Spektrum Service
4105 Fieldstone Road
Champaign, IL 61822

Include your complete name and address information inside the carton and clearly write it on the outer label/return address area. Include a brief summary of the problem. Date your correspondence and be sure that your name and address appear on this enclosure. To receive warranty service, you must include your original sales receipt verifying the proof-of-purchase date. Providing warranty conditions have been met, your equipment will be repaired at no charge or replaced at the discretion of Horizon Hobby.

FCC Information

This device complies with part 15 of the FCC rules. Operation is subject to the following two conditions: (1) This device may not cause harmful interference, and (2) this device must accept any interference received, including interference that may cause undesired operation.

Caution: Changes or modifications not expressly approved by the party responsible for compliance could void the user's authority to operate the equipment.

This product contains a radio transmitter with wireless technology which has been tested and found to be compliant with the applicable regulations governing a radio transmitter in the 2.400GHz to 2.4835GHz frequency range.

USA	Canada	Belgium
Denmark	France	Finland
Germany	Italy	Netherlands
Spain	Sweden	UK

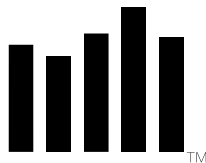

SPEKTRUMTM

HORIZON
H O B B Y

© 2005 Horizon Hobby, Inc.
4105 Fieldstone Road
Champaign, Illinois 61822
(877) 504-0233
horizonhobby.com